

IEEE Guide for the Application of Current Transformers Used for Protective Relaying Purposes

Sponsor
**IEEE Power System Relaying Committee
of the
IEEE Power Engineering Society**

Approved 18 April 1996
IEEE Standards Board

Approved 3 October 1996
American National Standards Institute

Abstract: The characteristics and classification of current transformers (cts) used for protective relaying are described. This guide also describes the conditions that cause the ct output to be distorted and the effects on relaying systems of this distortion. The selection and application of cts for the more common protection schemes are also addressed.

Keywords: current transformers, protective relaying

The Institute of Electrical and Electronics Engineers, Inc.

345 East 47th Street, New York, NY 10017-2394, USA

Copyright © 1995 by the Institute of Electrical and Electronics Engineers, Inc.

All rights reserved. Published 1996. Printed in the United States of America.

ISBN 1-55937-829-8

No Part of this publication may be reproduced in any form, in an electronic retrieval system or otherwise, without the prior written permission of the publisher.

IEEE Standards documents are developed within the IEEE Societies and the Standards Coordinating Committees of the IEEE Standards Board. Members of the committees serve voluntarily and without compensation. They are not necessarily members of the Institute. The standards developed within IEEE represent a consensus of the broad expertise on the subject within the Institute as well as those activities outside of IEEE that have expressed an interest in participating in the development of the standard.

Use of an IEEE Standard is wholly voluntary. The existence of an IEEE Standard does not imply that there are no other ways to produce, test, measure, purchase, market, or provide other goods and services related to the scope of the IEEE Standard. Furthermore, the viewpoint expressed at the time a standard is approved and issued is subject to change brought about through developments in the state of the art and comments received from users of the standard. Every IEEE Standard is subjected to review at least every five years for revision or reaffirmation. When a document is more than five years old and has not been reaffirmed, it is reasonable to conclude that its contents, although still of some value, do not wholly reflect the present state of the art. Users are cautioned to check to determine that they have the latest edition of any IEEE Standard.

Comments for revision of IEEE Standards are welcome from any interested party, regardless of membership affiliation with IEEE. Suggestions for changes in documents should be in the form of a proposed change of text, together with appropriate supporting comments.

Interpretations: Occasionally questions may arise regarding the meaning of portions of standards as they relate to specific applications. When the need for interpretations is brought to the attention of IEEE, the Institute will initiate action to prepare appropriate responses. Since IEEE Standards represent a consensus of all concerned interests, it is important to ensure that any interpretation has also received the concurrence of a balance of interests. For this reason, IEEE and the members of its societies and Standards Coordinating Committees are not able to provide an instant response to interpretation requests except in those cases where the matter has previously received formal consideration.

Comments on standards and requests for interpretations should be addressed to:

Secretary, IEEE Standards Board
445 Hoes Lane
P.O. Box 1331
Piscataway, NJ 08855-1331
USA

Note: Attention is called to the possibility that implementation of this standard may require use of subject matter covered by patent rights. By publication of this standard, no position is taken with respect to the existence or validity of any patent rights in connection therewith. The IEEE shall not be responsible for identifying all patents for which a license may be required by an IEEE standard or for conducting inquiries into the legal validity or scope of those patents that are brought to its attention.

Authorization to photocopy portions of any individual standard for internal or personal use is granted by the Institute of Electrical and Electronics Engineers, Inc., provided that the appropriate fee is paid to Copyright Clearance Center. To arrange for payment of licensing fee, please contact Copyright Clearance Center, Customer Service, 222 Rosewood Drive, Danvers, MA 01923 USA; (508) 750-8400. Permission to photocopy portions of any individual standard for educational classroom use can also be obtained through the Copyright Clearance Center.

Introduction

(This introduction is not part of IEEE Std C37.110-1996, IEEE Guide for the Application of Current Transformers Used for Protective Relaying Purposes).

This guide was prepared by the Guide for the Application of Current Transformers for Relaying Working Group of the Relay Inputs Sources Subcommittee of the IEEE Power System Relaying Committee. The guide is intended to assist relay engineers in understanding the operation of current transformers and their selection and application to specific relay protection schemes.

At the time this guide was approved, the working group membership was as follows:

M. W. Conroy, *Chair*
B. D. Nelson, *Vice Chair*

B. Bozoki
J. W. Chadwick, Jr.
G. K. Clough
P. R. Drum
L. L. Dvorak
I. O. Hasenwinkle
J. D. Huddleston, III

W. C. Kotheimer
J. R. Linders
M. J. McDonald
G. P. Moskos
C. C. Parr
R. Ryan
E. Sage

D. W. Smaha
K. A. Stephan
J. Stephens
J. T. Uchiyama
S. E. Zocholl

The following persons were on the balloting committee:

Mark Adamiak
John Appleyard
E. A. Baumgartner
Barbara L. Beckwith
R. W. Beckwith
G. Benmouyal
David C. Blackburn, Jr.
John Boyle
B. Bozoki
James A. Bright
J. Burnworth
H. J. Calhoun
Carlos H. Castro
Thomas W. Cease
John W. Chadwick, Jr.
S. R. Chano
Graham Clough
Stephen P. Conrad
Mark W. Conroy
Carey J. Cook
Albert N. Darlington
Douglas C. Dawson
R. W. Dempsey
C. L. Downs
Paul R. Drum
Lavern L. Dvorak
Walt Elmore
A. Elneweih
J. Esztergalyos
H. G. Farley

E. C. Fennell
C. W. Fromen
Jonathan D. Gardell
Jeffrey Gilbert
A. T. Giuliante
S. E. Grier
Edward M. Gulachenski
E. A. Guro
R. W. Haas
R. E. Hart
Irwin Hasenwinkle
C. F. Henville
J. W. Hohn
J. D. Huddleston, III
J. W. Ingleson
J. A. Jodice
Edward W. Kalkstein
Mladen Kezunovic
K. J. Khunkhun
W. C. Kotheimer
P. A. Kotos
John R. Linders
W. J. Marsh, Jr.
J. E. McConnell
M. J. McDonald
J. L. McElray
M. Meisinger
William M. Mello
R. J. Moran
Charles J. Mozina

K. K. Mustaphi
George R. Nail
B. D. Nelson
C. C. Parr
Robert D. Pettigrew
Arun G. Phadke
Alan C. Pierce
John M. Postforoosh
M. S. Sachdev
Evan T. Sage
Miriam P. Sanders
James E. Stephens
W. M. Strang
M. J. Swanson
Richard P. Taylor
James Teague
John T. Tengdin
James S. Thorp
Demetrios A. Tziouvaras
Joe T. Uchiyama
E. A. Udren
Vid Varneckas
Charles L. Wagner
William P. Waudby
Thomas E. Wiedman
P. B. Winston
K. Zimmerman
J. A. Zipp
Stan Zocholl
John A. Zulaski

When the IEEE Standards Board approved this standard on 18 April 1996, it had the following membership:

Donald C. Loughry, *Chair*
Richard J. Holleman, *Vice Chair*
Andrew G. Salem, *Secretary*

Gilles A. Baril
Clyde R. Camp
Joseph A. Cannatelli
Stephen L. Diamond
Harold E. Epstein
Donald C. Fleckenstein
Jay Forster*
Donald N. Heirman
Ben C. Johnson

E. G. "Al" Kiener
Joseph L. Koepfinger*
Stephen R. Lambert
Lawrence V. McCall
L. Bruce McClung
Marco W. Migliaro
Mary Lou Padgett
John W. Pope
Jose R. Ramos

Arthur K. Reilly
Ronald H. Reimer
Gary S. Robinson
Ingo Rüsçh
John S. Ryan
Chee Kiow Tan
Leonard L. Tripp
Howard L. Wolfman

*Member Emeritus

Also included are the following nonvoting IEEE Standards Board liaisons:

Satish K. Aggarwal

Alan H. Cookson

Chester C. Taylor

Rochelle L. Stern
IEEE Standards Project Editor

CLAUSE	PAGE
1. Overview	1
1.1 Scope	1
1.2 Purpose	1
2. References	1
3. Definitions	2
4. Current transformer characteristics and classification	3
4.1 Current transformer equivalent circuit and phasor diagrams	4
4.2 Current transformer secondary excitation characteristics	5
4.3 Knee-point voltage	6
4.4 Current transformer accuracy	7
4.5 Dynamic characteristics	11
4.6 The effects of remanence	15
4.7 Fundamental transformer equation	18
5. General application of current transformers	19
5.1 Current transformer burdens	19
5.2 Ratio selection	21
5.3 Long-term and short-term thermal ratings	21
5.4 Current transformer secondary output accuracy class voltage	22
5.5 Connecting current transformers in series	22
5.6 Three-phase connections	23
5.7 Auxiliary current transformers	23
5.8 Bus configuration	24
5.9 Current transformer location	25
5.10 Minimizing the effects of current transformer saturation	26
5.11 Determining current transformer steady-state performance using secondary excitation curves	26
6. Effects of current transformer saturation on relays	27
6.1 Saturation effects on electromechanical relays	27
6.2 Saturation effects on static relays	27
6.3 Saturation effects on differential relays	27
6.4 Unbalance current measurement	28
7. Specific applications of current transformers	28
7.1 Overcurrent relays	28
7.2 Differential protection	32
7.3 Distance protection	49
7.4 Other types of high-speed protection	50
Annex A IEC standards on current transformers (Informative)	51
Annex B List of IEEE standard C values and burdens (Informative)	53
Annex C Remanent flux in current transformers (Informative)	54
Annex D Bibliography (Informative)	55

IEEE Guide for the Application of Current Transformers Used for Protective Relaying Purposes

1. Overview

1.1 Scope

This standard describes the characteristics and classification of current transformers (cts) used for protective relaying. It also describes the conditions that cause the ct output to be distorted and the effects on relaying systems of this distortion. The selection and application of cts for the more common protection schemes are also addressed.

1.2 Purpose

The purpose of this document is to present a comprehensive treatment of the theory and application of cts to assist the relay application engineer in the correct selection and application of cts for protective relaying purposes.

2. References

This standard shall be used in conjunction with the following publications. When the following standards are superseded by an approved revision, the revision shall apply.

IEC 44-6 (1992), Instrument transformers—Part 6: Requirements for protective current transformers for transient performance.¹

IEC 185 (1987), Current transformers.

IEEE Std C37.103-1990, IEEE Guide for Differential and Polarizing Relay Circuit Testing (ANSI).²

¹IEC publications are available from IEC Sales Department, Case Postale 131, 3, rue de Varembe, CH-1211, Genève 20, Switzerland/Suisse. IEC publications are also available in the United States from the Sales Department, American National Standards Institute, 11 West 42nd Street, 13th Floor, New York, NY 10036, USA.

²IEEE publications are available from the Institute of Electrical and Electronics Engineers, 445 Hoes Lane, P.O. Box 1331, Piscataway, NJ 08855-1331, USA.

IEEE Std C57.13-1993, IEEE Standard Requirements for Instrument Transformers (ANSI).

IEEE Std 100-1992, The New IEEE Standard Dictionary of Electrical and Electronics Terms (ANSI).

3. Definitions

The following definitions are taken from IEEE Std 100-1992 except as noted. The symbol ^(a) indicates that at the time the standard was approved there was no corresponding definition in IEEE Std 100-1992. Symbol ^(b) indicates the definition was taken from British Standard B.S.3938, Specification for Current Transformers.

3.1 accuracy: The extent to which the current in the secondary circuit reproduces the current in the primary circuit in the proportion stated by the marked ratio, and represents the phase relationship of the primary current.

3.2 accuracy classes for relaying (instrument transformer): Limits in terms of percent ratio error that have been established.

3.3 accuracy ratings for relaying: The relay accuracy class is described by a letter denoting whether the accuracy can be obtained by calculation or must be obtained by test, followed by the minimum secondary terminal voltage that the transformer will produce at 20 times rated secondary current with one of the standard burdens without exceeding the relay accuracy class limit. (This is usually taken as 10%.)

3.4 burden (of a relay): Load impedance imposed by a relay on an input circuit, expressed in ohms and phase angle at specified conditions.

3.5 burden on an instrument transformer: That property of the circuit connected to the secondary winding that determines the active and reactive power at the secondary terminals. The burden is expressed either as total ohms impedance, together with the effective resistance and reactance components, or as the total voltamperes and power factor of the secondary devices and leads at the specified values of frequency and current.

3.6 bushing type current transformer: A current transformer that has an annular core with a secondary winding insulated from and permanently assembled on the core but has no primary winding or insulation for a primary winding. This type of ct is for use with a fully insulated conductor as a primary winding. A bushing type ct is usually used in equipment where the primary conductor is a component part of other apparatus.

3.7 continuous thermal current rating factor (RF): The specified factor by which the rated primary current of a ct can be multiplied to obtain the maximum primary current that can be carried continuously without exceeding the limiting temperature rise from 30 °C ambient air temperature. When current transformers are incorporated internally as parts of larger transformers or power circuit breakers, they shall meet allowable average winding and hot-spot temperatures under the specific conditions and requirements of the larger apparatus.

3.8 current transformer (ct): An instrument transformer that is intended to have its primary winding connected in series with the conductor carrying the current to be measured or controlled. In window-type cts, the primary winding is provided by the line conductor and is not an integral part of the transformer.

3.9 instrument transformer: A transformer that is intended to reproduce in its secondary circuit, in a definite and known proportion, the current or voltage of its primary circuit with the phase relations substantially preserved.

3.10 knee-point voltage (Class C transformers): The point on the excitation curve where the tangent is at 45° to the abscissa. The excitation curve shall be plotted on log-log paper with square decades. This definition is for nongapped cts. When the ct has a gapped core, the knee-point voltage is the point where the tangent to the curve makes an angle of 30° with the abscissa.^a

3.11 knee-point voltage: That sinusoidal voltage of rated frequency applied to the secondary terminals of the transformer, all other windings being open circuited, which, when increased by 10% causes the exciting current to increase by 50%.^b

3.12 marked ratio: The ratio of the rated primary value to the rated secondary value as stated on the nameplate.

3.13 multi-ratio ct: A ct from which more than one ratio can be obtained by the use of taps on the secondary winding.

3.14 multiple-secondary current transformer: A ct that has two or more secondary coils each on a separate magnetic circuit with all magnetic circuits excited by the same primary winding.

3.15 polarity: The designation of the relative instantaneous directions of the currents entering the primary terminals and leaving the secondary terminals during most of each half cycle. Primary and secondary terminals are said to have the same polarity when, at a given instant during most of each half cycle, the current enters the identified, similarly marked primary lead and leaves the identified, similarly marked secondary terminal in the same direction, as though the two terminals formed a continuous circuit.

3.16 rated primary current: Current selected for the basis of performance specification.

3.17 rated secondary current: The rated primary current divided by the marked ratio.

3.18 remanence: The magnetic flux density that remains in a magnetic circuit after the removal of an applied magnetomotive force.

NOTE — This should not be confused with *residual flux density*. If the magnetic circuit has an air gap, the remanence will be less than the residual flux density. *See:* residual flux density.

3.19 residual flux density: The magnetic flux density at which the magnetizing force (H) is zero when the material is in a symmetrically, cyclically, magnetized condition. *See:* remanence.

3.20 saturation factor (K_s): The ratio of the saturation voltage of a current transformer to the excitation voltage. Saturation factor is an index of how close to saturation a current transformer is in a given application.^a

3.21 saturation voltage (V_x): The symmetrical voltage across the secondary winding of the current transformer for which the peak induction just exceeds the saturation flux density. It is found graphically by locating the intersection of the straight portions of the excitation curve on log-log axes. This is not the same as the knee-point voltage which is the point on the curve where the tangent to the curve makes an angle of 45° to the abscissa.^a

3.22 time-to-saturation: The time during which the secondary current is a faithful replica of the primary current.^a

NOTE — The core does not saturate suddenly. Beyond the saturation flux level, the exciting current increases more rapidly than the secondary current, causing distortion in the secondary waveform.

3.23 transactor: A magnetic device with a gapped core having an input winding that is energized with an alternating current and having an output voltage that is a function of the input current. The term transactor is a contraction of the terms *transformer and reactor*.^a

3.24 turns ratio of a current transformer: The ratio of the secondary winding turns to the primary winding turns.

3.25 window-type current transformer: A ct that has a secondary winding insulated from and permanently assembled on the core, but has no primary winding as an integral part of the structure. Complete insulation is provided for a primary winding in the window through which one turn of the line conductor can be passed to provide the primary winding.

3.26 wound-type current transformer: A ct that has a primary winding consisting of one or more turns mechanically encircling the core or cores. The primary and secondary windings are insulated from each other and from the core(s) and are assembled as an integral structure.

4. Current transformer characteristics and classification

Faults on power systems cause transients in the system currents, which modify the steady state behavior of cts. Both steady state and transient conditions, therefore, must be considered when examining the characteristics of cts.

4.1 Current transformer equivalent circuit and phasor diagrams

4.1.1 Current transformer equivalent circuit

Figure 1 shows a simplified equivalent circuit of a ct and its connected burden. The primary leakage impedance and the reactive part of the secondary leads do not substantially affect calculations and are, therefore, neglected.

4.1.2 Phasor diagram of a current transformer with burden

To construct the phasor diagram for a ct, the procedure is as follows:

- a) Start with the secondary load current I_S
- b) Draw the secondary volt drops: $I_S \times R_S$ and $I_S \times X_L$
- c) Add V_B to the resultant voltage in order to obtain the internal secondary exciting voltage V_S
- d) When V_S has been obtained, draw the flux phasor lagging V_S by 90°
The exciting current, I_E , is composed of the magnetizing current, I_M , which is needed to generate the flux in the ct core, and the loss current, I_{LOSS} , which is mainly due to the hysteresis and eddy current losses
- e) Draw the magnetizing current, I_M , in quadrature with the voltage and the resistive loss current, I_{LOSS} , in phase with the secondary exciting voltage

$$I_M + I_{LOSS} = I_E$$

$$I_{ST} = I_S + I_E$$

The primary current is then

$$I_P = \left(\frac{N_2}{N_1}\right)(I_S + I_E)$$

where

N_2/N_1 the turns ratio

Figures 2 and 3 show the phasor diagrams for a resistive burden (power factor of 1.0) and a standard burden (power factor of 0.5).

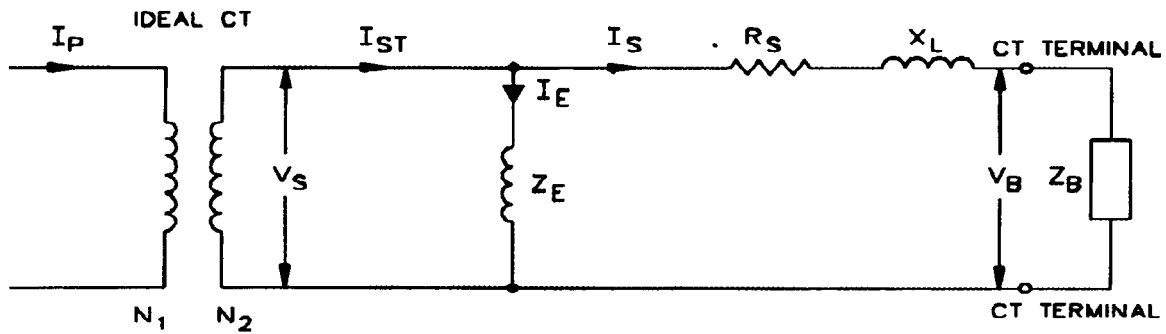

- V_S is the secondary exciting voltage
- V_B is the ct terminal voltage across external burden
- I_P is the primary current
- Z_E is the exciting impedance
- I_{ST} is the total secondary current
- R_S is the secondary resistance
- I_S is the secondary load current
- X_L is the leakage reactance (negligible in Class C cts)
- I_E is the exciting current
- $N_2:N_1$ is the ct turns ratio
- Z_B is the burden impedance (includes secondary devices and leads)

Figure 1—Equivalent circuit of a current transformer

4.2 Current transformer secondary excitation characteristics

When the voltage developed across the ct burden is low, the exciting current is low. The waveform of the secondary current will contain no appreciable distortion. As the voltage across the ct secondary winding increases because either the current or the burden is increased, the flux in the ct core will also increase. Eventually the ct will operate in the region where there is a disproportionate increase in exciting current. The ct core is entering the magnetically saturated region; operation beyond this point will result in an increasing ratio error and a distorted secondary current waveform.

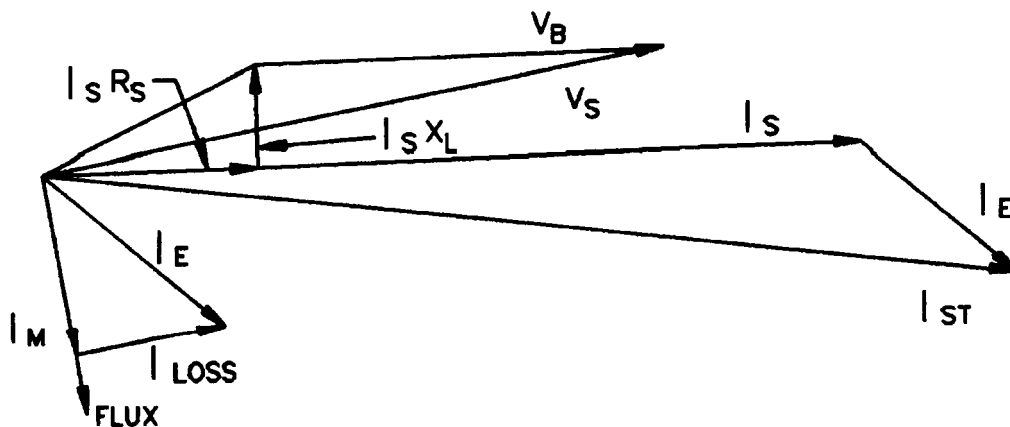

Figure 2—Phasor diagram of a current transformer with a resistive burden

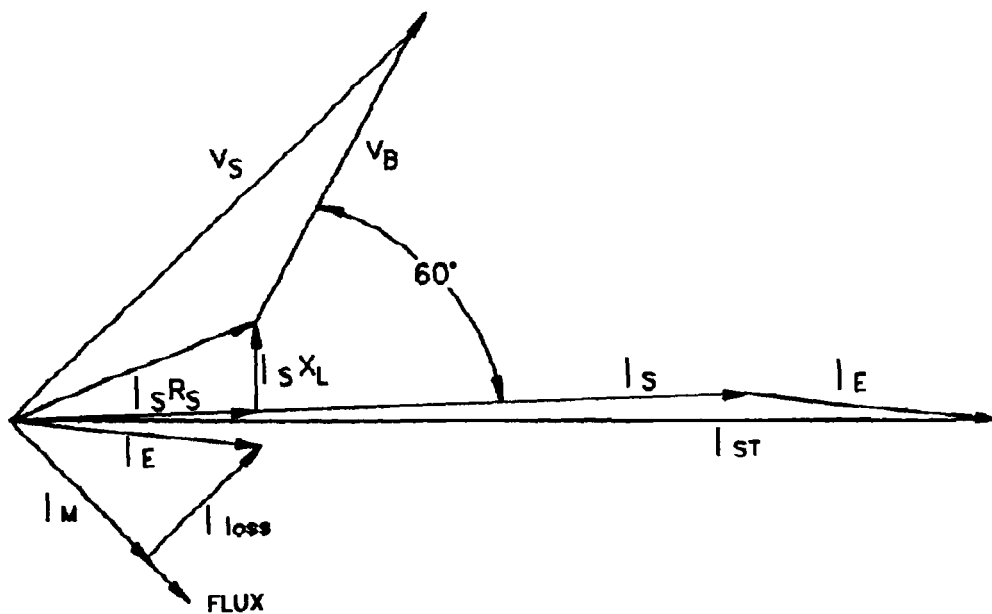

Figure 3—Phasor diagram of a current transformer with a standard burden (0.5 power factor)

CT operation is illustrated by using excitation curves. These curves show the relationship of secondary exciting voltage (V_E) to the excitation current (I_E). A typical set of excitation curves for a C class ct is shown in figure 4. The curves are plotted on log-log coordination paper and are developed from test data. The primary winding shall be open circuited for this test. Curve tolerances are stated in figure 4. More specific information concerning construction of excitation curves is found in 6.10 and 8.3 of IEEE Std C57.13-1993.

4.3 Knee-point voltage

The knee-point voltage of a ct with a nongapped core is defined as the point of maximum permeability on the excitation curve, plotted on log-log axes with square decades, where the tangent to the curve makes a 45° angle with

the abscissa. This is shown in figure 4 and gives a knee-point for the 1200/5 A winding of about 240 V. When the ct has a gapped core, the definition of the knee-point voltage is the point where the tangent to the curve makes an angle of 30° with the abscissa.

4.4 Current transformer accuracy

The ANSI ct accuracy class is determined by a letter designation and a secondary terminal voltage rating. These effectively describe the steady-state performance. (See IEEE Std C57.13-1993, 6.4.1.)³ The secondary terminal voltage rating is the ct secondary voltage that the ct will deliver when it is connected to a standard secondary burden, at 20 times rated secondary current, without exceeding a 10% ratio error. Furthermore, the ratio correction shall be limited to 10% at any current from 1 to 20 times rated secondary current at the standard burden or any lower standard burden. The voltage rating given applies to the full winding ratio only. If a tap is utilized on a multi-ratio ct, the voltage capability is directly proportional to the ratio between the tap value being used and the full winding capability, provided the windings are fully distributed around the core. This is usually the case with cts made after 1978, but not necessarily with cts made before that date.

For example, ct accuracy class C100 means that the ratio error will not exceed 10% at any current from 1 to 20 times rated secondary current with a standard 1.0 Ω burden (1.0 Ω times 20 times rated secondary current equals 100 V). Almost all of the cts used for protective relay applications are covered by the C or K classification. This includes bushing cts with uniformly distributed windings and other cts with minimal core leakage flux.

NOTE — IEEE standard C values and standard burdens are listed in annex B.

The letter designation codes are as follows:

- C indicates that the leakage flux is negligible and the excitation characteristic can be used directly to determine performance. The ct ratio error can thus be calculated. It is assumed that the burden and excitation currents are in phase and that the secondary winding is distributed uniformly. (See 8.1.10 of IEEE Std C57.13-1993 for further detail.)
- K is the same as the C rating, but the knee-point voltage must be at least 70% of the secondary terminal voltage rating.
- T indicates that ratio error must be determined by test. The T class ct has an appreciable core flux leakage effect and contributes to appreciable ratio error.
- H, L are old ANSI classifications. There were two accuracy classes recognized—2.5% and 10%. Cts were specified in the following manner—10 L 200, 2.5 H 400, etc. The first number indicated the accuracy class and the last number indicated the secondary voltage class. L cts were rated at the specified burden and at 20 times normal current. H cts were rated at any combination of burden from 5 times to 20 times the normal current. These ratings are applicable only to old cts mostly manufactured before 1954.

³Information on references can be found in clause 2.

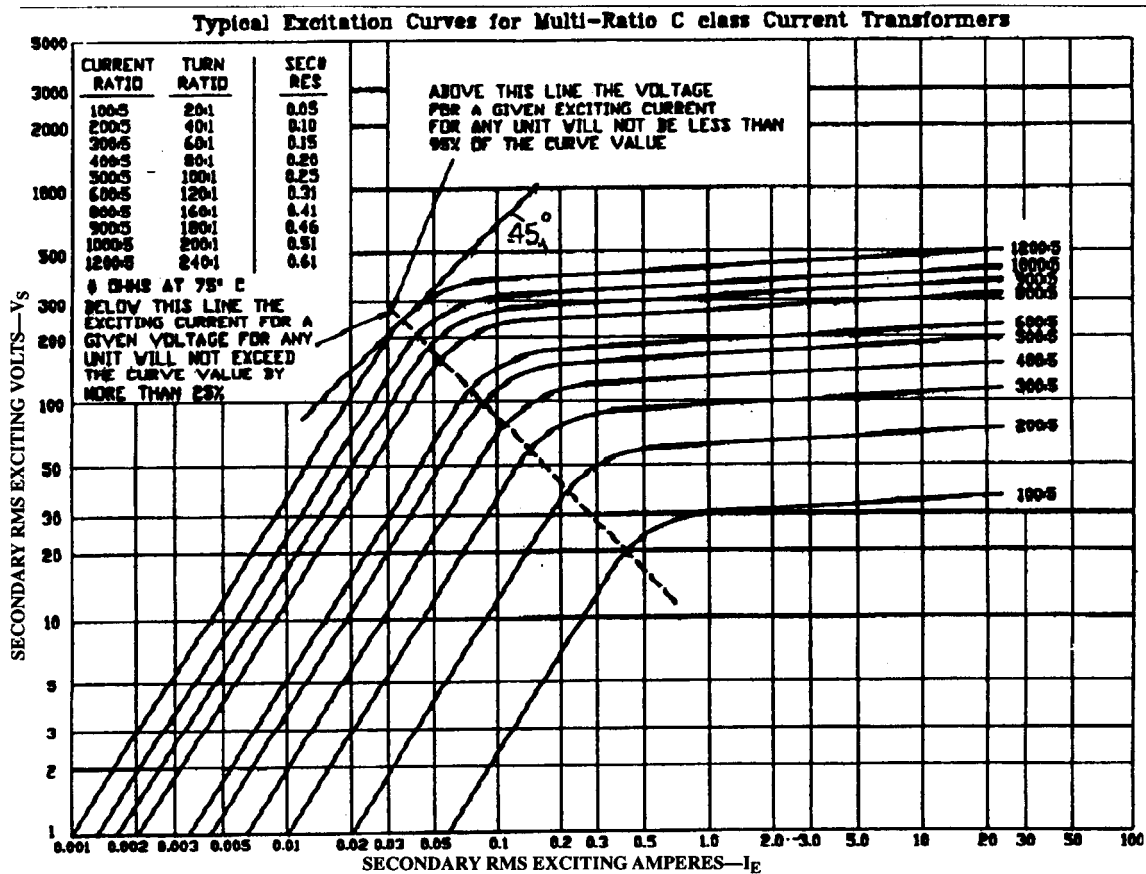

Figure 4—Typical excitation curves for a multi-ratio C class current transformer

4.4.1 Determination of the C or K classification using the excitation curve

Figure 1 shows the ct secondary winding, the secondary winding resistance, R_S , and a connected burden, $Z_B \cdot I_E$ is the excitation current, and I_S is the secondary load current through the burden.

Set $I_E/I_S = 0.1$ to define a 10% error (I_E and I_S are assumed to be in phase). For the 1200:5 ct in figure 4,

$$I_S = 100 \text{ A (20 times rated secondary current)}$$

$$I_E = 10 \text{ A}$$

The secondary exciting voltage, V_S for the full-ratio winding, corresponding to $I_E = 10 \text{ A}$, is obtained from the excitation curve. Figure 4 shows that with $I_E = 10 \text{ A}$, V_S is 500 V. Although the standard burdens involve power factor, a quick arithmetic (worse case) calculation of the secondary terminal voltage, V_B , may determine the classification since the standard voltage values for 5 A secondaries are 10 V, 20 V, 50 V, 100 V, 200 V, 400 V, or 800 V (see annex B).

From figure 1: $V_B = V_S - (I_S \times R_S)$ (X_L is negligible)

$$V_S = 500 \text{ V}$$

$$R_S = 0.61 \text{ } \Omega \text{ (from figure 4)}$$

$$I_S \times R_S = 100 \times 0.61 = 61 \text{ V}$$

$$V_B = 500 - 61$$

$$V_B = 439 \text{ V}$$

By selecting the next lowest classification voltage, this ct is determined as having a C400 classification.

If the arithmetic calculation of V_B is marginal with respect to a standard classification voltage, a more exact check should be done with a standard burden, Z_B , at 0.5 pF. For the ct shown in figure 4 at a standard 4 Ω burden:

$$\begin{aligned} V_S &= I_S \times (R_S + Z_B) && \text{(refer to figure 1)} \\ &= 100 \times (0.61 + 2.0 + j3.464) \\ &= 261 + j346.4 \\ &= 434 \text{ V } \angle 53^\circ \end{aligned}$$

Referring to figure 4 for $V_S = 434 \text{ V}$, I_E , is approximately 2.0 A. The error, I_E/I_S , is about 2% so the ct has a classification of C400 because at this secondary terminal voltage ($V_B = I_S \times Z_B = 400 \text{ V}$), the error is < 10%.

4.4.2 Examples of using the accuracy classification to assess steady-state current transformer performance

Example 1:

A 1200/5, C400 ct with excitation curves, shown on figure 4, is connected to a 2.0 Ω burden. Based on the accuracy classification, what is the maximum symmetrical fault current that may be applied to this ct without exceeding a 10% ratio error?

Answer:

Based on the criteria that the ct can deliver 20 times rated secondary current without exceeding a 10% ratio error, the maximum fault current will be 24 000 A. However, with a 2.0 Ω burden, this will result in a voltage below the knee-point of the ct and, as a practical matter, it will be within 10% accuracy at higher currents. This can only be accurately determined from excitation or ratio correction curves and not from the accuracy classification. For example, a ct with characteristics shown on figure 4 will produce between 180–240 A without exceeding the 10% ratio error, depending on the power factor of the 2.0 Ω burden.

Example 2:

A 1200/5, C400 ct is connected on the 1000/5 tap. What is the maximum secondary burden that can be used and still maintain rated accuracy at 20 times rated symmetrical secondary current?

Answer:

Since the secondary voltage capability is directly proportional to the connected tap, the ct will support a voltage of $1000/1200 \times 400 \text{ V}$ or 333 V. Twenty times rated secondary current is 100 A. Therefore, the maximum burden is 333 V/100 A or 3.33 Ω .

4.4.3 Determination of percent error and ANSI voltage classification for "T" class cts using overcurrent ratio curves

For "T" class cts, the secondary leakage reactance is not negligible. For this reason, IEEE Std C57.13-1993 requires manufacturers to provide overcurrent ratio curves for these cts on rectangular coordinate paper plotted in terms of

primary versus secondary current from 1 to 22 times rated primary current for all standard burdens up to the burden that causes a ratio correction of 50%. Figure 5 is a typical overcurrent ratio curve for a "T" class ct.

The percent error of a T class ct can easily be computed from an overcurrent ratio curve for any standard burden and a known primary current using the following relationship:

$$\% \text{ error} = \left[\left(\frac{\text{Multiples of rated primary current}}{\text{Multiples of rated secondary current}} \right) - 1 \right] \times 100$$

Example 1: From figure 5, find the percent error of a T class ct with a 4 Ω standard burden carrying 17 times rated primary A. When "times rated primary current" equals 17, then "times rated secondary current" equals 13 at the intersection of 17 with the 4 Ω curve.

$$\therefore \% \text{ error} = \left(\frac{17}{13} - 1 \right) \times 100\% = 30.77\%$$

The ANSI voltage accuracy rating can also be determined from a T class overcurrent ratio curve. By trial and error, find the ratio of "times rated primary current" to 20 times rated secondary current starting with the lower standard burden and incrementing to the next higher burden until the percent error calculated exceeds 10%. The burden with the percent error no greater than 10% is the one with which to classify the ANSI accuracy voltage rating.

Example 2: From figure 5, find the ANSI accuracy voltage rating of this 5 A rated T class ct.

Assume 2 Ω standard burden

When $I_S = 20 \times$ rated secondary current, then

$I_P = 22 \times$ rated primary current

$$\% \text{ error} = \left(\frac{22}{20} - 1 \right) \times 100\% = 10\%$$

Voltage rating = $20 \times 5 \times 2 = 200$ V

Therefore, the ct can also be classified as a T200 where the 10% error is implied.

All higher burdens will exceed 10% error. Therefore, the ANSI classification is not applicable in this case for the 4 Ω and 8 Ω burdens.

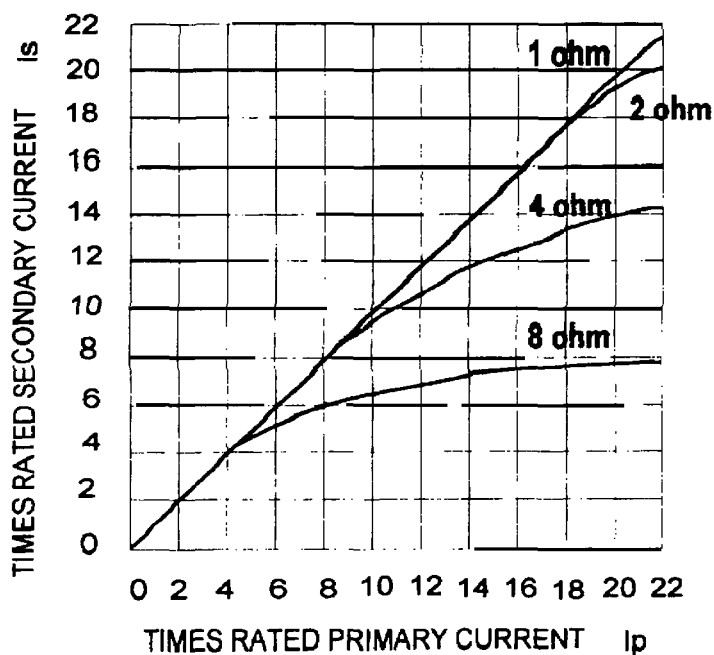

Figure 5—Overcurrent ratio curve

4.5 Dynamic characteristics

4.5.1 Flux change with asymmetrical primary current

The dc component of an asymmetrical current greatly increases the flux in the ct. When the dc offset is at a maximum, the ct flux can potentially increase to $1 + X/R$ times the flux resulting from the sinusoidal, or non-offset component, where X and R are the primary system reactance and resistance to the point of the fault [B11]⁴.

The difference between the non-offset and offset flux is illustrated in figures 6 and 7. In figure 6, there is remanent flux but no offset in the primary current. The ct core does not go into the saturated region of operation so the secondary current is undistorted. Figure 7 shows the resulting flux and secondary current when the primary current is fully offset. The increase in flux is not instantaneous, indicating that saturation does not occur instantaneously but takes time. This time is called the *time-to-saturation*.

⁴The numbers in brackets preceded by the letter B correspond to those of the bibliography in annex D.

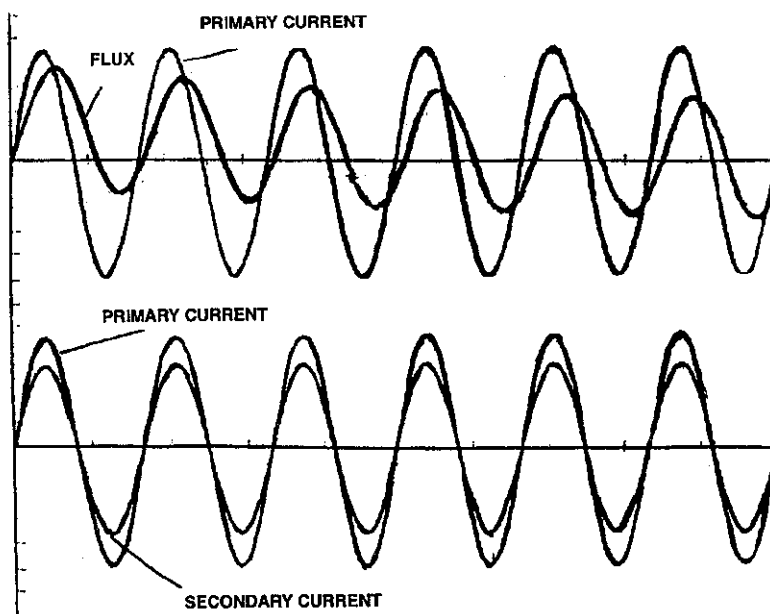

Figure 6—Relationship between primary current and flux and between primary current and secondary current for a nonsaturated current transformer

4.5.2 Saturation factor and time-to-saturate

If practical, the effects of saturation can be avoided by sizing the ct to have a knee-point voltage above that required for the maximum expected fault current and ct secondary burden, with suitable allowance for possible dc component and remanence. The knee-point voltage may be 50% to 75% of the standard accuracy class voltage rating of the ct (e.g., C 400). Saturation can be avoided by observing the following:

- a) To avoid ac saturation, the ct shall be capable of a secondary saturation voltage, V_X :

$$V_X > I_S \times Z_S$$

where

I_S is the primary current divided by the turns ratio, and Z_S is the total secondary burden ($R_S + X_L + Z_B$).

- b) To avoid saturation with a dc component in the primary wave and with a pure resistive burden, the required saturation voltage is

$$V_X > I_S \times Z_S \left(1 + \frac{X}{R} \right)$$

where

X and R are the primary system reactance and resistance up to the point of fault [B11].

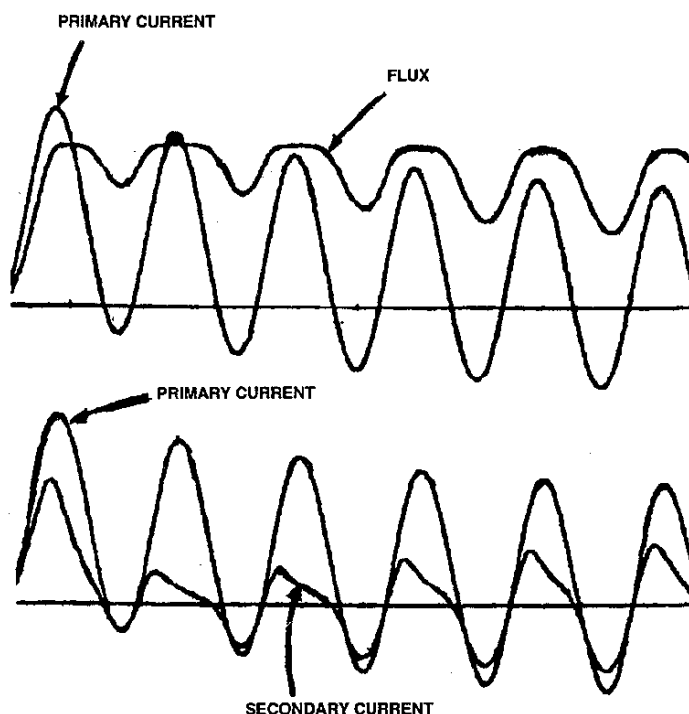

Figure 7—Relationship between primary current and flux and between primary current and secondary current for a saturated current transformer

If the ct burden is also inductive, the required saturation voltage to avoid saturation caused by primary dc is

$$V_X > I_S \times Z_S \left(1 + \frac{X}{R} \times \frac{R_S + R_B}{Z_S} \right)$$

To also account for possible premagnetization (in the worst direction)

$$V_X > \frac{I_S \times Z_S \left(1 + \frac{X}{R} \times \frac{R_S + R_B}{Z_S} \right)}{1 - \text{per unit remanence}}$$

These requirements generally result in impractically large cts and hence compensating steps must be taken to minimize saturation effects on the relay protection plan. Some high speed instantaneous relays can operate before saturation has time to occur.

4.5.2.1 Saturation voltage

The saturation voltage (V_X) is that symmetrical voltage across the secondary winding of the ct for which the peak induction just exceeds the saturation flux density.

4.5.2.2 Saturation factor

The ratio of the saturation voltage to the excitation voltage is defined as The Saturation Factor K_S and is an index of how close to saturation a ct is in a given application. It is used to calculate the time-to-saturate under transient conditions.

4.5.2.3 Time-to-saturation

Time-to-saturation is important in the design and application of protective relays. A ct will often be capable of accurately replicating offset primary currents for one or two cycles before the ct core starts to enter the region of distorted operation. The time-to-saturation of a ct is determined by the following parameters:

- a) *Degree of fault current offset.* The system X/R ratio and the fault-incidence angle determine the degree of offset in the primary current waveform. As described above, the dc component contributes an increase in flux; the greater the degree of offset, the sooner the core will reach the onset of saturation.
- b) *Fault current magnitude.* For the same degree of offset, the magnitude of the offset current is proportional to the magnitude of the sinusoidal current component. The greater the magnitude, the faster the increase in the flux to the point of saturation.
- c) *Remanent flux in the ct core.* Remanent flux in the ct core will add to, or subtract from, the flux produced by other mechanisms, depending on their relative polarities. When the remanent flux results in an increase, the time-to-saturation is shortened. In cases of very high remanent flux, the ct may be effectively saturated almost from the beginning. Subclause 4.6 covers this subject in more detail.
- d) *Secondary circuit impedance.* All other factors being equal, a ct with a higher total secondary burden of the same power factor will have a shorter time-to-saturation. This is because the higher burden demands a higher voltage at a given current and the flux is proportional to the voltage. For two impedances of the same magnitude, the one with the more inductive component (lower pF) will give a longer time-to-saturation because the inductance has a low impedance to the dc offset current, reducing the burden voltage drop and associated flux.

A second characteristic of inductive burdens is their tendency to saturate at high secondary currents. The effect is to reduce the burden volt drop, which reduces the flux and increases the time-to-saturation. When an inductive burden is added to a ct circuit, the magnitude of the overall ohmic burden is not substantially increased (even if saturation of the burden is ignored) because the impedances are added as vectors rather than as scalars.

- e) *Saturation voltage.* The secondary excitation impedance of a ct depends upon the quantity and quality of the iron in the core. The larger the cross section of the core of the ct, the more flux is required to saturate it. This results in a higher saturation voltage. All other factors being equal, the time-to-saturation will be longer.
- f) *Turns ratio.* The fundamental measure of ct saturation is the degree that flux density exceeds the saturation flux density level. For a given core area and primary current, increasing the turns ratio of a ct decreases the flux and, thereby, reduces the flux density. The reduction in flux may be visualized as the result of two effects.

Firstly, since $E = n \times d\Phi/dt$, an increase in turns reduces the amount of flux necessary to produce a given secondary EMF. Stated another way, saturation occurs at a proportionally higher voltage when the number of secondary turns is increased.

Secondly, an increase in turns reduces the secondary current for a given primary current, since the secondary current varies inversely with the turns ratio. If the secondary ohmic burden were to remain unchanged, the required secondary voltage would also vary inversely with the turns ratio. In practice, the ohmic burden of the secondary circuit will increase to some extent if the ct ratio is increased.

- The winding resistance of the secondary winding is proportional to the number of turns and therefore increases with an increase in the turns ratio.
- The use of a higher turns ratio may require the use of a more sensitive, higher burden relay or relay tap, particularly if an electromechanical relay is employed.
- The ohmic burden of the secondary wiring between the ct and the relay typically does not change with an increase in ct ratio since the conductors are not resized for the lower current.

Thus, while the net effect of a lower secondary current is, in general, a lower secondary voltage requirement, how much lower will depend on the details of the specific case.

The combination of the two effects (more EMF per unit of flux and lower secondary current) is a substantial decrease in core flux for an increase in turns ratio. This also results in an increase in time-to-saturation.

The considerations above are intended to apply to choosing the best ct ratio on a multi-ratio ct. When specifying cts, it should be kept in mind that a manufacturer may use a smaller core in a higher ratio ct to meet the same accuracy class requirement, since accuracy classes are specified in terms of voltage, not flux. With a smaller core, the ct has a greater tendency to saturate. To avoid this dilemma, the ct can be specified to have a higher accuracy class or a C800 accuracy class can be required for a lower ratio than the full-winding ratio.

IEEE Publication 76 CH1130-4 PWR contains curves from which the time-to-saturation can be calculated. The basic equation covering this is

$$T_S = -T_1 \ln \left(1 - \frac{K_S - 1}{R} \frac{X}{R} \right)$$

$$T_1 = \frac{X}{\omega R}$$

where

- \ln is the natural log function
- T_S is the time-to-saturation
- T_1 the primary system time constant
- K_S the saturation factor V_X/V_S , where V_X is the saturation voltage and, in this case, V_S is defined as $V_S = I_S (R_S + R_B)$
- ω is $2\pi f$, where f is the system frequency
- X is the reactance of the primary system to the point of the fault
- R is the resistance of the primary system to the point of the fault

4.6 The effects of remanence

The remanent flux in a ct core depends on the flux in the core immediately before primary current interruption. The magnitude of the flux is determined by the value of symmetrical primary current, the dc offset, and the impedance of the secondary circuit. Maximum remanent flux is obtained when the primary current is interrupted while the transformer is in a saturated state. In addition, testing that requires dc to flow in the transformer winding will cause remanence.

Once remanent flux is established, it is dissipated very little under service conditions. A voltage of about 60% of the knee-point voltage shall be applied to reduce the remanence to less than 10% of saturation flux density.

The remanent flux will, therefore, remain in the core until it is demagnetized.

4.6.1 Output of a ct with remanence

When the remanent flux is of the opposite polarity to the flux due to the transient component of the fault current, the ct tends to produce an undistorted secondary current. If the remanent flux is of the same polarity as the flux due to the transient component of the fault current, then a distorted secondary waveform is probable.

Figure 8 shows three waveforms representing the output current of a ct with and without remanence. These waveforms relate to a typical C800 1200/5 ct. The fault current in each case is 24 000 A and the dc offset has a time constant of 0.05 s ($X/R = 19$) and maximum amplitude. The total burden for all three traces is $1.6 + j0.7 \Omega$. Waveforms A, B, and C show the ct behavior with remanent flux of 0%, 50%, and 75%, respectively. The time-to-saturate in each case is 1.5 cycles, 0.5 cycles, and 0.3 cycles, respectively.

Since remanent flux as high as 80% of saturation flux can be obtained, and has been measured in cores of cts (see annex C), the total burden capability of a transformer with such high remanence will be correspondingly reduced. Since the resistance of the transformer secondary winding is a part of the total burden, the burden external to the transformer would have to be reduced to a very small value to avoid transient saturation of the ct core.

4.6.2 Reducing remanence in cts

The only way of reducing remanence in ct cores that are presently in service is to demagnetize them by external means. Such demagnetization can be performed using power frequency voltage. With the primary winding open circuited, a source of variable voltage is connected across the secondary winding and increased until the core starts to enter the saturated region. This point can be detected by observing the disproportionate increase in exciting current. Reduction of the voltage to zero over a period of about 3 s will demagnetize the core. A ct in service and carrying load may be demagnetized by inserting a variable resistor in the secondary circuit, increasing its resistance to achieve core saturation, and then reducing the resistance to zero. Complete avoidance of loss of performance due to remanence, would require demagnetization of ct cores after each major disturbance. However, as this is a practical impossibility, the effects of remanence must be taken into account. CTs should be demagnetized after a continuity check or resistance measurement. The prevention of accidental saturation of cts by test instrumentation would require special continuity testers and resistance measuring instruments.

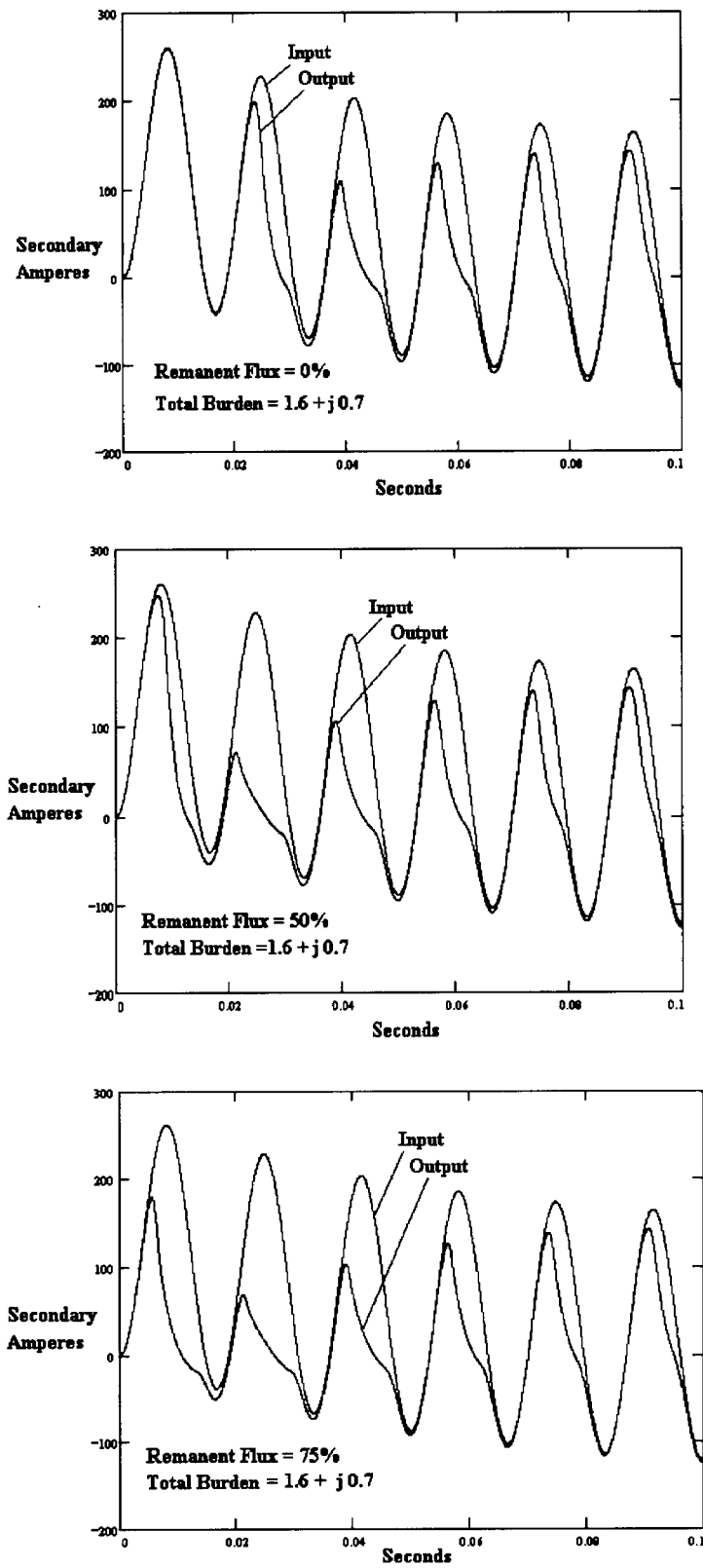

Figure 8—Secondary waveforms with increasing remanent flux

The remanence in new transformers can be controlled in several ways. These include the use of

- a) Different grades of steel for the core
- b) Gapped cores
- c) Biased core cts

These measures will be discussed in turn as follows:

- a) Cold-rolled, grain-oriented, silicon steel is the core material used for almost all relaying cts. This material can have remanence as high as 80% of its saturation flux density. Hot-rolled silicon steel does not have as high a permeability or as low losses as the cold-rolled steel, but its maximum remanence is approximately half of the cold-rolled steel.
- b) The use of a gapped core in a ct has two effects on its performance. It increases the magnetizing current and reduces the possibility of remanence. It can be shown that the increase in magnetizing current due to a small gap will have no effect on the relaying accuracy rating of a ct but the remanence will be reduced to a very small value. CTs with large gaps in their cores, sometimes referred to as linearized cores, have little or no remanence.
- c) The biased-core ct consists of a core made of two equal sections. By a suitable arrangement of bias windings and a dc power supply, one core section is magnetically biased to approximately 75% of the maximum flux density in the positive direction while the other core section is magnetically biased in the negative direction. The transformer operates as a conventional transformer except for the flux resetting action of the bias windings. This resetting action guards against any remanence being left in the core. The obvious disadvantages of this type of transformer are the bias windings and the requirement for a dc power supply. It should be pointed out that the failure of the dc power supply does not affect the operation of the transformer as such, but only its flux resetting action. The transformer performance then reverts to that of a conventional ct.

4.7 Fundamental transformer equation

The fundamental transformer equation is

$$\frac{V}{N} = \frac{B_m A f}{22.51 \times 10^2}$$

where

- V/N is the volts per turn, which is the same in both windings
 B_m is the maximum flux density in the core (tesla)
 A is the effective cross sectional area of the core, cm^2
 f is the frequency (Hz)

The ideal ct operates with an ampere-turn balance such that

where

$$N_1 I_P = N_2 I_S$$

where

- N_1 is the number of primary turns
 N_2 is the number of secondary turns

However, exciting current is needed to generate the flux, which produces the secondary voltage. This will produce a ratio error that is sometimes corrected by putting fewer turns on the core than the equation above demands. The extra secondary current compensates for the exciting current. The formula is useful for estimating the cross sectional area where the volts per turn are proportional to the area of the core. Application of the fundamental transformer equation requires the use of information on ct iron flux density characteristics and cross sectional area. Where this information is available, analysis using a computer program is the best approach.

5. General application of current transformers

Under ideal conditions, the secondary current developed by a ct will be an exact replica of the primary current. However, the ct secondary current will not be a sine wave when the flux in the ct core reaches into the saturated region. The factors affecting this are

- a) Secondary burden
- b) Primary current
- c) Asymmetry in the primary current
- d) Remanent flux in the ct core

The accuracy rating used in classifying cts is not a recommended operating point as it is simply a convenient method for specifying the steady-state voltage that the ct is required to produce. A more useful ct parameter is the knee-point voltage (see 4.3).

5.1 Current transformer burdens

Higher ohmic burdens in the ct secondary circuit will tend to result in greater saturation of the core, and therefore, larger errors in the secondary current waveform. The reason for this is that a given secondary current requires more voltage from the ct for a higher burden, and the core flux density is proportional to the time-integral of this voltage. When the core becomes saturated, significant current is diverted through the cts magnetizing branch, and the desired secondary current is reduced and distorted. Burden calculations are, therefore, necessary to ensure that ct accuracy limits are not exceeded.

The total ohmic burden on the ct is the vector sum of the ct winding resistance, the connecting lead resistance, the impedance of any auxiliary cts, and the impedance of the connected relays and meters. Impedances of devices connected in the secondary of an auxiliary ct should be reflected (multiplied by the square of the auxiliary ct ratio) to the primary side, when calculating the burden on the main ct. This is only accurate if the auxiliary ct is not saturated.

As a first check in making the burden calculation, it is common practice to add the individual burdens arithmetically rather than vectorially. In many cases, this approach is very accurate, particularly if the ct winding resistance and the connecting lead resistance comprise the bulk of the secondary burden. However, if this method predicts poor ct performance, and if information on burden power factor is available, the less conservative, but more complicated, vectorial method should be used.

Electromechanical relays are usually subject to saturation themselves, at high currents. Coil impedances at the currents of interest (as opposed to rated current) should be used in the burden calculation. A table of burdens vs, current (burdens may be expressed either in ohms or volt-amperes) is usually provided in the relay instruction book, but information on the power factor is often incomplete. In this case, it is customary to assume a purely resistive burden.

With the ohmic burden determined, the next step in predicting ct performance is to determine the required ct excitation voltage by multiplying the calculated total ohmic burden (using the magnitude, in the case of vector quantities) by the maximum expected secondary fault current. The ct excitation characteristic is then used to determine the excitation current. The higher the excitation current, as a proportion of the expected secondary current, the worse will be the actual replication of the primary current waveform. If errors greater than 10% are indicated (or more conservatively, if

the calculated excitation voltage is above the knee-point), then the application is suspect and measures to reduce the burden are advised.

Sample burden calculation

Consider the 1200/5 ct of figure 4 applied under conditions of a 24 000 A maximum fault current as illustrated in figure 9. First consider the circuit without the auxiliary ct and then with the auxiliary ct.

The relay time-overcurrent unit is to be set for 5 A, and the instantaneous unit for 40 A. The secondary current under maximum fault conditions is expected to be $24\ 000/240 = 100$ A.

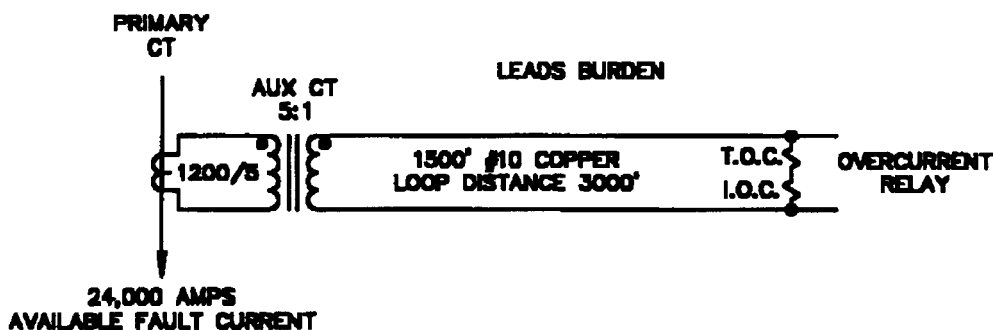

Figure 9—Burden calculation

1200/5 ct: From figure 4, the winding resistance is $0.61\ \Omega$

1500 ft of #10 wire: $1500\ \text{ft} \times 1.0\ \Omega/1000\ \text{ft} \times 2 = 3.0\ \Omega$.

TOC unit: The relay instruction book indicates a burden of 490 VA at 20 times tap-value (5 A), or $0.049\ \Omega$.

IOC unit: The instruction book indicates a burden of $0.007\ \Omega$ for this unit.

Total burden: The scalar addition of all burdens (a fairly accurate approach which also simplifies calculations), results in $0.61 + 3.0 + .049 + 0.007$, or about $3.7\ \Omega$.

The required excitation voltage is, therefore, $3.7 \times 100 = 370$ V. This is well above the knee-point voltage of the ct, and is at best a marginal application.

Consider now the same application with the addition of a 5:1, T200 auxiliary ct.

Auxiliary ct: According to the manufacturer, the internal burden of the auxiliary ct is 1.11 VA at 5 A. The ohmic burden is, therefore, $1.11\ \Omega$ on the secondary side.

TOC unit: The reduced current requires that the TOC unit now be set on the 1 A tap. The burden at 20 times tap-value current is given as 265 VA, or $0.66\ \Omega$

IOC unit: The IOC unit burden at the new tap setting is given as $0.125\ \Omega$.

Total burden on the auxiliary ct: Again using a scalar addition, the secondary burden on the auxiliary ct is $1.11 + 3.0 + 0.66 + 0.125$, or $4.9\ \Omega$. The required excitation voltage from the auxiliary ct is 4.9×20 , or 98 V, well within the capability of a T200 ct.

Total burden on the main ct: Reflected to the primary the auxiliary ct secondary burden is $4.9/25$, or 0.196Ω . The total burden on the main ct is, therefore, $0.61 + 0.196$, or 0.81Ω . The required excitation voltage on the main ct is now 81 V, representing a dramatic reduction compared with the previous example.

It should be pointed out that in general, other factors such as dc offset in the primary current waveform, ct remanence, the operating characteristics of the connected relays etc., should also be considered. This may result in a requirement for better cts (or smaller connected burdens) than calculations of the above type would indicate.

5.2 Ratio selection

In general, ct ratios are selected to match the maximum load current requirements, i.e., the maximum design load current should not exceed the ct rated primary current. The highest ct ratio permissible should usually be used to minimize wiring burden and to obtain the highest ct capability and performance. The ct ratio should be large enough so that the ct secondary current does not exceed 20 times rated current under the maximum symmetrical primary fault current.

The use of low ratio cts on low current rated circuits, where fault current levels are very high, presents problems of reduced ct capability, the possibility of very high secondary currents, and ct saturation. These effects can be minimized by using the highest ct ratio that is compatible with low current range relays and instruments. Where the fault level exceeds 20 times the ct secondary rated current, an additional higher ratio ct should be used with an instantaneous relay.

5.3 Long-term and short-term thermal ratings

The ct ratio should be selected so that, for maximum primary load current, the secondary current produced does not exceed the continuous thermal current rating of any part of $\sqrt{3}$ the ct total secondary circuit.

Most cts have a nominal continuous secondary current rating of 5 A, but higher ratings can be specified. These ratings are specified by the standard rating factor. Values of the standard rating factor are 1.0, 1.33, 1.5, 2.0, 3.0, and 4.0 (See IEEE Std C57.13-1993, 6.5).

Cables and wire leads will usually have a greater ampacity than the ct secondary because other considerations determine cable and wire size. Relays and other devices in the secondary current circuit must be checked to make sure that their thermal ampacity rating will not be exceeded by maximum primary load current. It should be noted that delta connected cts produce currents in the cables and relays that are times the ct secondary currents.

While high currents for short-circuit conditions are expected to last for a relatively short time, system failures can result in longer fault duration. The energy dissipated in the ct secondary windings and the cables is generally not a concern because of the relatively high thermal capacity. In very high current applications, it should be verified that the short time thermal capability of relays will not be exceeded. The short time rating of relays is generally specified by the manufacturer and should be in accordance with the ct short time ratings in IEEE Std C57.13-1993. This usually follows the expression $I^2t = \text{constant}$, where I is the current in amperes and t is the time in seconds. However, the maximum through fault current should not exceed 20 times the ct rating to maintain accuracy.

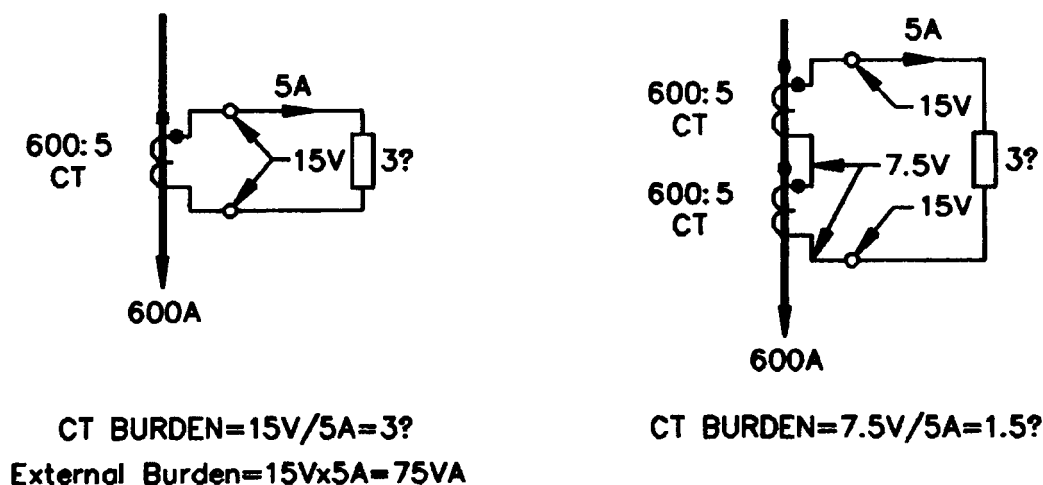

Figure 10—CT connected in series

5.4 Current transformer secondary output accuracy class voltage

The ct accuracy class voltage should be chosen so that the ct secondary output will be sufficient to ensure proper performance of the associated relays. The proper relay performance must be defined by the protection engineer for the particular application of the relay. The evaluation of ct accuracy depends on the magnitude of the primary short circuit current, ct ratio selected, ct accuracy class (C, K, or T), ct excitation characteristics including saturation, and secondary circuit burden. In all cases, the application should be checked to ensure that waveform distortion does not occur under conditions of maximum symmetrical fault current.

For differential applications, ct performance to ensure restraint for external faults may be most important in selecting ct accuracy class voltage. For line protection, ct performance for close-up faults may be the most important criterion.

The highest available ratio on a multi-ratio ct will provide up to the rated voltage output (such as 800 V for a C800 ct) to drive the secondary current through the secondary burden. For C or K class cts, lower ratios will provide proportionally lower capability, while at the same time requiring more secondary current to be driven into the burden. Therefore, lower ct ratios produce rapidly diminishing accuracy performance due to the dual effect of higher currents and lower output voltage capability.

In general, the highest possible ct ratio will produce the best accuracy performance but at the possible expense of sensitivity.

5.5 Connecting current transformers in series

This connection is *not* recommended for new installation; however, it may be present in some existing installations. It is better to use one ct with good performance or reduce the burden on the ct. Cts in series must be identical and physically next to each other to avoid faults between them.

CAUTION — If a primary fault should occur between the two cts, excessive overvoltage can result. Secondary overvoltage protection may be required. An example would be the use of a ct from each side of a breaker and a flashover occurring between the breaker contacts and the case of the breaker. The current in the cts would be in opposite directions, therefore, excessive overvoltage occurs on each ct.

The addition of a second identical ct in series results in the following changes (see figure 10):

- a) The burden (volt-ampere) requirement is divided between the two cts.
- b) The burden *voltage* capability is doubled.
- c) The burden impedance placed on each ct is *one half* the external connected burden impedance.

Therefore, when two cts with similar excitation characteristics are connected in series, the excitation voltage of each ct is reduced by 50% and the excitation current is also reduced. The burden voltage capability is doubled.

5.6 Three-phase connections

In three-phase ct connections, the burden on individual cts varies with the type of connection and the type of fault as shown in the following table:

Table 1—Fault type effects on burden

Connection	Type of fault	
	3 Ph or ph-to-ph	Ph-to-ground
Wye (connected at ct)	$Z = R_S + R_L + Z_R$	$Z = R_S + 2R_L + Z_R$
Wye (connected at switchhouse)	$Z = R_S + 2R_L + Z_R$	$Z = R_S + 2R_L + Z_R$
Delta (connected at switchhouse)	$Z = R_S + 2R_L + 3Z_R$	$Z = R_S + 2R_L + 2Z_R$
Delta (connected at ct)	$Z = R_S + 3R_L + 3Z_R$	$Z = R_S + 2R_L + 2Z_R$
<p>Z is the effective impedance seen by the ct R_S is the ct secondary winding resistance and ct lead resistance; also includes any relay impedance that is inside the delta connection (ohms) R_L is the circuit one-way lead resistance (ohms) Z_R is the relay impedance in the ct secondary current path (ohms)</p>		

Optimum ct performance will be obtained from the connection that provides the lowest overall burden.

5.7 Auxiliary current transformers

Auxiliary cts are used for the following reasons:

- a) Circuit isolation to permit independent grounding
- b) Change in ratio to match current requirements
- c) To produce a phase shift in a three phase circuit
- d) To reverse polarity
- e) To limit main ct fault burden by saturating during faults
- f) To reduce the burden on the main ct by reducing the apparent impedance of a portion of the burden by the square of the auxiliary ct ratio
- g) Zero sequence shunt or trap

The auxiliary ct should be selected with an adequate continuous current rating and voltage capability for the requirements of its connected burden. The addition of an auxiliary ct adds burden to the main ct, but the net effect on the main ct may be either a decrease or an increase in burden, depending on whether the current is stepped down or up. The apparent impedance to the main ct of the portion of the burden in the secondary of the auxiliary ct is that portion multiplied by the square of the auxiliary ct ratio. For example, a 1.0 Ω burden in the secondary of a 2:1 auxiliary ct would appear as 0.25 Ω to the main ct, but would appear as 4.0 Ω for a 1:2 auxiliary ct. For this reason, current step-up applications should be avoided when practical.

To ensure good performance under fault conditions, the knee-point voltage of the auxiliary ct should be considered in relation to its connected burden, without regard to the knee-point voltage of the main ct. However, an auxiliary ct with an unnecessarily high knee-point voltage may have an undesirably high internal burden, which is seen directly by the main ct.

If circuit isolation is not required, it is advantageous to use auxiliary cts in the autotransformer connection for maximum capability or minimum burden. The use of the autotransformer connection usually results in better transient response. Ratios that are not available with a two winding arrangement can be obtained using the autotransformer arrangement. Figure 11 shows how additional ratios can be obtained with 5:5 A, 10:5 A, and 15:5 A two-winding auxiliary cts connected as autotransformers. Only the step down ratios are shown. Stepping up current with auxiliary cts is not usually good practice as the connected burden will be increased as the square of the turns ratio of the auxiliary ct.

5.8 Bus configuration

A single line or transformer per breaker offers the simplest consideration of maximum primary load currents. Here, the primary of the ct sees the same current as the line or transformer.

For ring bus and breaker-and-a-half applications, the ct ratio needs to be adequate for the maximum through-flow requirements. The desired ct ratio for the circuit connected between two breakers may be lower. If so, the main cts should be connected in parallel at their maximum ratio and an autotransformer-connected auxiliary ct used to feed the circuit relays or a lower tap used on the main ct. Performance of the lower tap of the main ct should be weighed against the performance using an auxiliary ct.

A second approach is to select cts and secondary circuit elements that have sufficient thermal rating and burden capability. CT taps can then be based on load and short-circuit considerations for the line without the use of auxiliary cts.

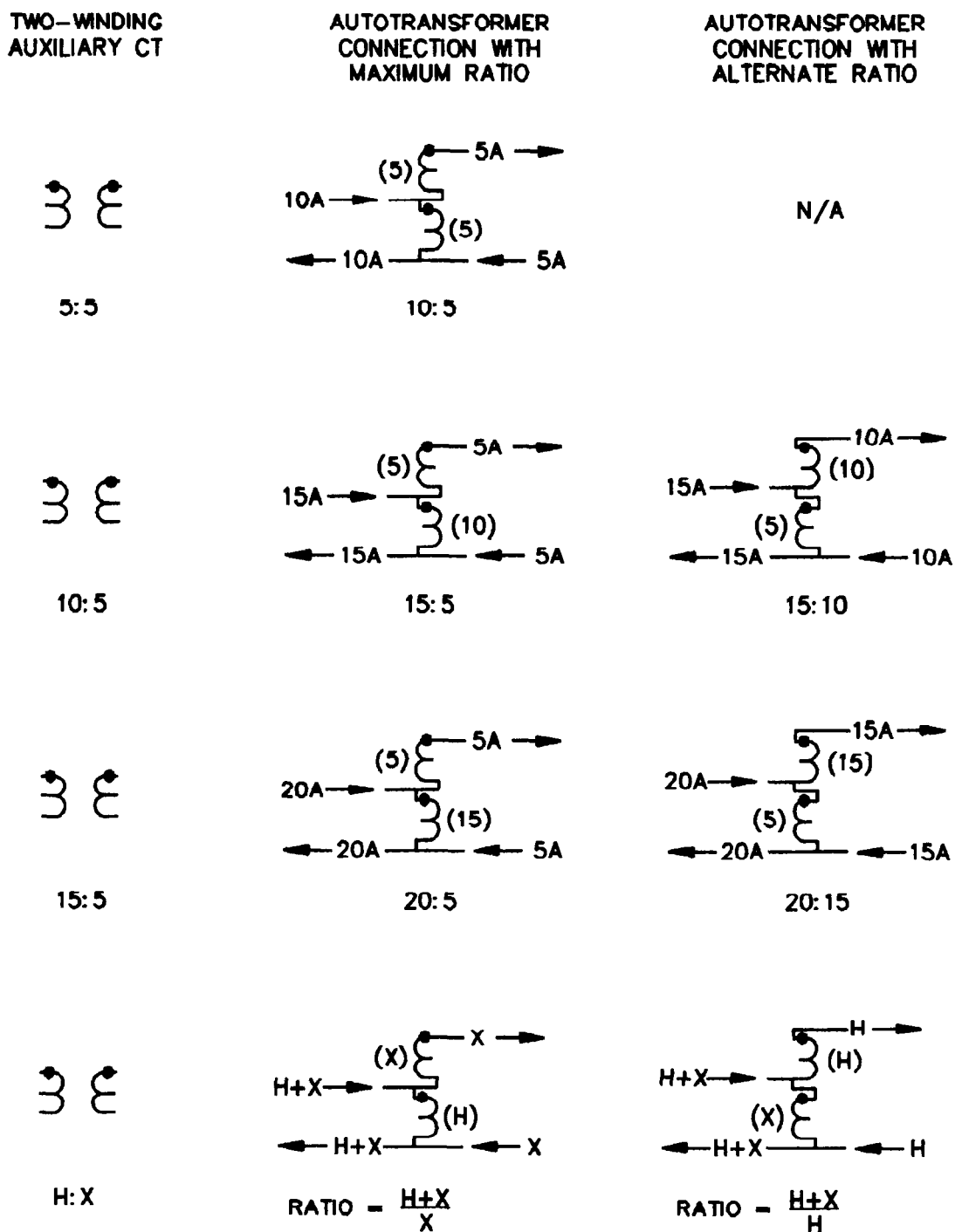

Figure 11—Two-winding auxiliary cts connected as autotransformers

5.9 Current transformer location

It is customary when using dead tank breakers to place cts on both sides of the contacts so that the protection zones will overlap. When live tank breakers are used, the cts are usually freestanding and located on only one side of the breaker.

The availability of breaker failure protection can determine which side of the breaker is best for ct location. A fault occurring between the breaker and the ct assembly may not be detected by the main protection. All possibilities of fault position should be considered and the location of the ct chosen for the fastest overall fault clearance.

5.10 Minimizing the effects of current transformer saturation

Generally, the performance specification for protective relays only covers operation at fundamental frequency sinusoidal currents. A rule of thumb frequently used in relaying to minimize the ct saturation effects is to select a ct with a C voltage rating at least twice that required for the maximum steady-state symmetrical fault current.

A discussion of methods to avoid ct saturation altogether is given in 4.5.2.

When metering instruments are used on the same cts as relays, the ct ratio should be sized for the relay needs and auxiliary ct used to bring the metering ratio to the desired value. The metering circuit burden is reflected through the auxiliary ct by the square of the turns ratio and added to the auxiliary ct burden. Both are minimized by selecting an auxiliary ct that will saturate at several times the maximum load current. This will minimize the metering burden on the main cts under heavy fault current. It also reduces the likelihood of the meters being damaged during a severe fault. Damage can occur when the cts have ratios suitable for meters and the ct C voltage rating has been chosen for relaying.

5.11 Determining current transformer steady-state performance using secondary excitation curves

The secondary excitation method provides a means of developing a curve that relates primary current to secondary current. Current transformer tap, secondary lead length, and relay burden can all be incorporated into the calculations.

Example 1:

Assume the secondary burden in a relay circuit is 5 Ω . The relay setting is 2 A and the ct ratio is 300/5. Using figure 4, calculate the primary current required to operate the relay.

$$V_B = 5 \Omega \text{ times } 2 \text{ A} = 10 \text{ V}$$

The secondary exciting current, from Figure 4, is approximately 0.04 A.

$$\begin{aligned} I_P &= N(I_{ST}) \\ &= N(I_E + I_S) \\ &= 300/5(0.04 + 2)\text{A} = 122 \text{ A} \end{aligned}$$

Example 2:

A relay is expected to operate for a 7000 A primary current. The ct ratio is 600/5. Secondary burden is 3.5 Ω . What is the error for the ct shown in figure 4?

The total secondary fault current is $(7000/600) \times 5 = 58 \text{ A}$. Assume the exciting current is negligible.

$$\begin{aligned} V_S &= I_S(R_B + R_S) \\ &= 58(3.5 + 0.31) \\ &= 221 \text{ V} \end{aligned}$$

The exciting current will not be negligible, however, and the calculation will need to be iterated.

From figure 4, this voltage would require an excitation current of approximately 5 A, giving a relay current of $58 - 5 = 53$ A. But this would need an exciting voltage of $53 \times 3.81 = 202$ V and an exciting current of 1 A.

For the second iteration, try $I_E = 2$ A.

$$V_S = 56 \text{ A} \times 3.81 \text{ } \Omega = 213 \text{ V}$$

From figure 4, $I_E \approx 2$ A

The ratio error is, therefore, $2/58$ or about 3.4%.

6. Effects of current transformer saturation on relays

6.1 Saturation effects on electromechanical relays

The performance of a relay for nonsinusoidal currents cannot be predicted without a detailed knowledge of the operating principles of the relay. Electromechanical relays operate on a value of current related to the rms value of the applied current. However, relays that develop an operating torque through internal phase-shifted fluxes may perform differently because of different phase shifts for different component frequencies of the distorted current.

Electromechanical relays tend to saturate at high currents. This reduces the relay burden on the ct, so that the ct performance at moderately high currents may be considerably better than the performance predicted from the relay's rated burden at 5 A.

CTs take time to enter the nonlinear region of operation; therefore, instantaneous relays can sometimes be set to operate if the relays respond faster than the occurrence of saturation. On the other hand, instantaneous relays, which operate in one to two cycles, may not operate at all during extreme ct saturation because the short pulse of current from the ct in each half cycle may last less than 1 ms.

6.2 Saturation effects on static relays

Static relays fall into two main categories—those relays that use an analog of the input current for processing the signal, and those relays in which analog to digital converters are used. Analog type relays respond to the average, not the rms, value of current. The response of digital relays is a function of the operation of the relay software. For a given waveshape, the difference can be compensated for, but a universal correction is not practical. This difference should be considered particularly when applying both electromechanical and static relays in a coordinated scheme. Except when stated otherwise, a manufacturer's relay performance data should be assumed to be based on sine wave steady-state rms values. Static instantaneous relays may perform differently than electromechanical instantaneous relays when subjected to saturated cts and offset fault currents.

6.3 Saturation effects on differential relays

The effect of ct saturation on differential relays depends on the type of relay and on whether the fault is external or internal to the protected zone. For internal faults, differential relays of any type shall be designed and applied such that they will operate either despite the presence of distorted waveforms, or prior to their onset. The more prevalent concern is the possible misoperation of differential relays for external faults.

Relays of the percentage differential type have some immunity to misoperation on severe external faults because their operating characteristic requires a substantial ratio of operate current to restraint current. Some percentage differential relays are also restrained by harmonic currents that are characteristic not only of transformer inrush (which is why they are used), but also of ct saturation, either of which conditions will cause undesired current to flow in the operate circuit.

of a differential relay. However, since the presence of harmonics may then delay or prevent operation on severe internal faults, it is customary to include a high-set, unrestrained overcurrent unit in the operate circuit of these relays.

If set properly, differential relays of the high-impedance type are immune to ct saturation during external faults; in fact, they are set not to trip assuming complete saturation of the ct with the highest primary current.

6.4 Unbalance current measurement

Unequal saturation of cts in three phases can result in incorrect indication of unbalance current in the secondary currents, where lower level, or no such unbalance exists in the primary currents. Unequal saturation can be caused by unequal amounts of transient dc component in the primaries, unequal amounts of low-frequency currents in the primaries, or use of different ct types or manufacturers, or accuracies or burdens between the three phases.

The incorrect indication of unbalance current can result in incorrect operation of negative sequence, or residually connected zero sequence overcurrent relays. Incorrect indication of unbalance conditions can be minimized by using cts with similar excitation characteristics and burdens in all three phases.

In some cases, even when balanced ct accuracies and burdens are used, incorrect indication can still occur. For instance, some single-phase tripping and reclosing line protection systems may depend on the presence of zero sequence current to indicate the presence of a single line to ground fault. Close-in three-phase faults will have different amounts of transient dc component in the primary currents, which may result in different performance of the three-phase cts, and incorrect indication of zero-sequence current. For protection schemes where the possibility of significant incorrect indication exists, special designs such as modification of zero-sequence level detectors by portions of positive sequence current may be used.

Shunt reactor protection systems may also suffer from incorrect indication of unbalance currents [B7]. Some systems rely on negative or zero sequence current to indicate the presence of turn to turn faults in the reactor. When the reactor is energized, there may be large and long lasting transient dc components in the phase currents (due to the high X/R ratio of the reactor). The level of dc component is usually different in each of the three phases, and unequal saturation of the three-phase cts may result. The effect of unequal saturation may be minimized by use of a ct in the neutral to ground primary connection of the reactor for zero sequence current measurement, and by time delays after energization for negative sequence current measurement.

7. Specific applications of current transformers

7.1 Overcurrent relays

7.1.1 Non-directional phase and ground overcurrent relays

The time current characteristics used in a coordinated system can minimize, but not eliminate, possible coordination errors due to the effects of ct saturation on relay performance. On a radial system, backup relays are generally supplied from higher ratio cts than the primary downstream relays. The backup relaying cts will, therefore, be less likely to saturate. The primary relays on the saturated cts will probably operate more slowly due to the distorted secondary current waveform. Necessary coordination may be lost.

An example where this may happen is when a transformer in an older station is replaced with a larger transformer. See figure 12. The cts on the distribution feeder breakers could have a low accuracy class of C200 or C400. With the higher fault current supplied by the larger transformer, the cts on the distribution breakers may saturate for feeder faults.

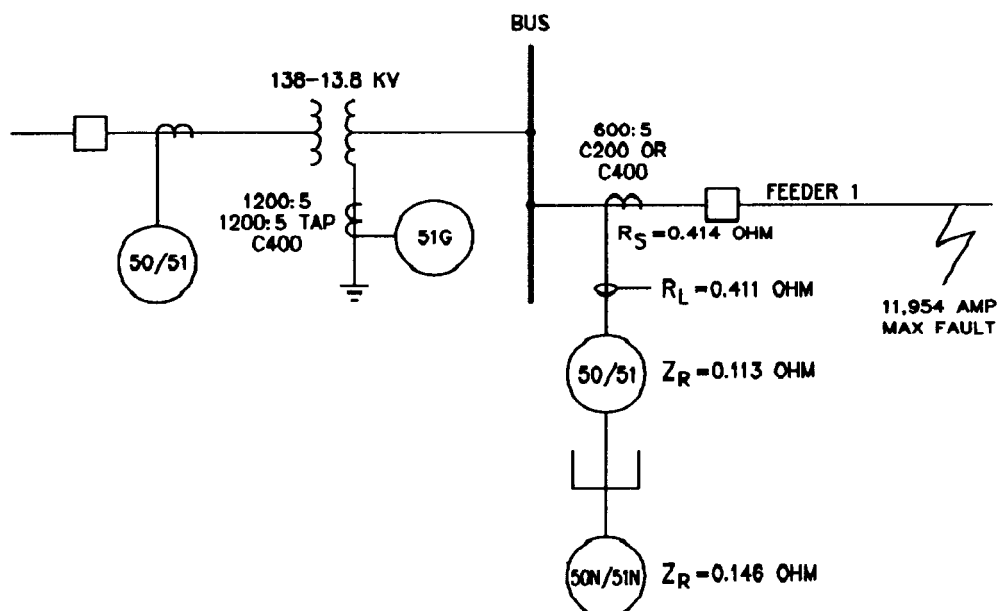

Figure 12—Nondirectional phase and ground overcurrent relays

Assume a worst case condition such as a close-in line-to-ground fault on a distribution feeder and an infinite system source behind the transformer. In this case, the three-phase and line-to-ground fault current would be the same, 11 954 A at 13.8 kV.

From table 1, the effective ct burden seen by the feeder breaker's cts for a line-to-ground fault is $Z = R_S + 2R_L + Z_R$. (Assume cts connect in wye at the ct.) Therefore, the necessary internal voltage to drive the ct secondary current through the burden is equal to

$$V_S = I_S \times Z$$

where

$$\begin{aligned} V_S &= \frac{11\,954}{120} \times (0.414 + 2(0.411) + 0.113 + 0.146) \\ &= 99.6 \times 1.50 \\ &= 149 \text{ V} \end{aligned}$$

If the feeder breaker cts are rated C200 with a knee point of about 100 V then they will saturate, produce distorted secondary current, and therefore, cause slower operation of the feeder electromechanical overcurrent relay.

Any unexpected loss of coordination can be minimized by one of the three following methods:

- Additional coordination time can be included in the settings.
- A less inverse relay time curve can be used upstream from the relay which has the saturated cts. This permits a greater time margin at high currents when saturation is more likely to occur.
- Set the instantaneous units below the current at which saturation begins to severely affect the speed of the time overcurrent units. This assumes that instantaneous tripping is enabled throughout the reclosing sequence.

If the cts are rated C400, the ct performance will be satisfactory for symmetrical faults because the knee point voltage is above 149 V and nearly 200 V.

7.1.2 Phase directional overcurrent relays

The directional unit in a voltage polarized directional phase-overcurrent relay is more sensitive than the overcurrent relay it controls. For this reason, it is less affected by ct saturation. The polarizing voltage reacts with the fundamental component of the operating current. During ct saturation, the fundamental component of the current is reduced in magnitude and advanced in phase angle; however, these effects are not usually enough to prevent operation of the unit because of its sensitivity.

7.1.3 Ground directional overcurrent relays

The directional element of most directional electromechanical ground overcurrent relays is polarized by either zero-sequence voltage or zero-sequence current. When the unit is polarized by current, the reference current is usually obtained from cts in the neutral of delta-wye connected transformers or in the tertiary winding of autotransformers.

If load current is taken from the delta-connected tertiary winding, cts in each phase of the tertiary winding shall have their secondaries connected in parallel to provide only the zero-sequence current ($3I_0$) for ground relay polarizing. If there is little or no load current on the tertiary, only a single ct is necessary to provide zero-sequence (I_0) current. Three cts with their secondaries in parallel will provide a higher polarizing current magnitude than a single ct of the same ratio; however, the single ct ratio may be lowered to increase the polarizing current if necessary.

In those cases where a suitable source of zero-sequence voltage or current cannot be obtained, it is necessary to use negative sequence directional units for the ground overcurrent relays. The ratio selected should be sufficient to provide adequate negative sequence current in the relay for ground faults at the end of the protected line section. Microprocessor based relays frequently use negative sequence polarizing developed internal to the relay.

Another case where it may be necessary to use negative sequence polarizing is when mutual coupling causes current reversals in the neutral of a grounded wye-delta transformer. This will generally occur when the respective zero-sequence networks of two parallel lines are isolated except for the mutual coupling between them. A ground fault on one line induces a zero-sequence current flow in the parallel line. At one end of the parallel line, current will flow from the ground to neutral and through the windings of grounded wye-delta transformers, as expected. At the other end, however, current will flow in the opposite direction, i.e., from neutral-to-ground. The latter case will result in incorrect ground relay polarization. When using pilot schemes, if negative sequence polarizing is required at one-end of a line, it is preferable to use it at both ends to ensure correct coordination.

7.1.3.1 Suitability of current sources for ground polarizing

In the rare instance where one leg of the transformer zero sequence T equivalent impedance is negative and greater in magnitude than the system zero-sequence source connected to that terminal of the transformer, the tertiary winding is not a suitable source for ground relay polarizing. See figure 13. The polarity of the tertiary current would reverse for fault current flowing through the transformer. Situations where this would occur generally involve small or high impedance transformers connected to strong systems.

Through fault current in the common winding of an autotransformer can flow in either direction. This current flow can cause confusion in verifying the polarity of the tertiary cts. To determine the proper polarity of the tertiary ct connections, the transformer contribution or polarizing current flowing in the tertiary should be considered to flow from the ground into the winding in a manner identical to the neutral current of a delta-wye transformer.

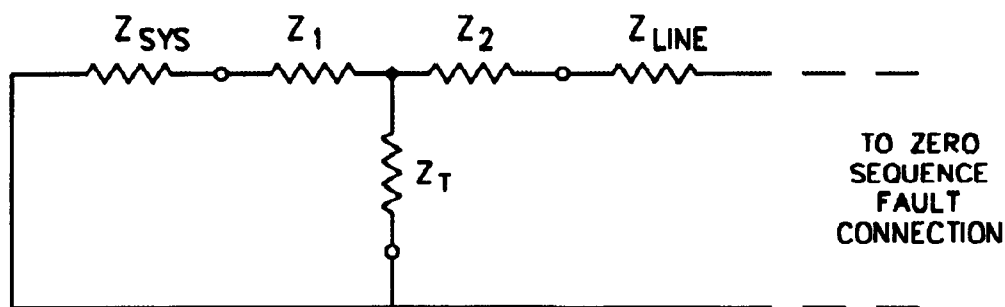

- Z_{sys} is the system zero-sequence source impedance
- Z_1 is the autotransformer T equivalent zero-sequence impedance, winding No. 1
- Z_2 is the autotransformer T equivalent zero-sequence impedance, winding No. 2
- Z_T is the autotransformer tertiary T equivalent zero-sequence impedance
- Z_{line} is the line or connected system zero-sequence impedance

If Z_1 is:	Is $ Z_1 > Z_{sys} $?	Autotransformer tertiary polarizing source direction is
positive	yes	correct
positive	no	correct
negative	yes	wrong!
negative	no	correct

Figure 13—Zero-sequence current polarizing for autotransformer T equivalent impedance

7.1.3.2 Current polarization from the neutral of three-winding transformers and autotransformers

Three-winding transformers are usually connected either wye-delta-wye or delta-delta-wye. Polarizing current may be obtained from the neutral of a delta-delta-wye in the same manner as a two winding delta-wye transformer. This is also true of a wye-delta-wye transformer where only one of the wye winding neutrals is grounded. A wye-delta-wye transformer with both wye winding neutrals grounded, however, requires a ct in each neutral with the secondaries connected in parallel and with the relative ratios that are the inverse of the relative ratios of the main transformer windings.

The neutral of an autotransformer is frequently unsuitable as a source of polarizing current since, as stated above, the current in the common winding can change directions for faults on the high and low side of the transformer. Therefore, an autotransformer neutral should only be used after a careful analysis of the direction of current flow in each winding during fault conditions.

7.1.3.3 Multiple ground polarizing current sources

Where there is more than one polarizing current source in a station, cts are often paralleled from each available source. This permits outages on any of these sources without affecting the directional ground relays. The ct ratios used in this case should be low enough to produce adequate polarizing current for remote faults during outage conditions and high enough to prevent excessive currents during close-in faults. The ct ratios for the several polarizing sources should be selected to provide approximately equal secondary currents to minimize the effect of the outage of one source. As a general rule, the maximum current in each relay's polarizing circuit should be limited to 100 A.

7.1.4 Toroidal flux summation or ring type cts

Ground fault relaying on industrial switchgear is commonly provided by an instantaneous relay connected to an open window ring type ct. All three phases of the primary pass through the same window. The ct ratio is commonly 50/5 A with a low accuracy classification such as C10. Ground fault currents may be limited to 1200 A or less by added resistance in the transformer neutral. This helps prevent dc offsets. The low ratio makes a low relay tap selection unnecessary. It is not necessary to use sensitive relay taps because of the low ratio; however, the ct performance should be checked using the burden of the relay at the tap selected. The relay short-time rating should be checked at the maximum fault current available.

7.1.5 Instantaneous overcurrent relays

If a ct saturates for any fault current above the relay's instantaneous element setting, a check should be made to determine that the time-to-saturate at the minimum saturation current and at the maximum current available are sufficient to permit instantaneous relay operation. See 4.5.2.

7.2 Differential protection

7.2.1 General

The principle of differential protection is to compare currents flowing into the protected zone to those flowing out of the protected zone in order to determine if the fault is internal or external to the zone.

There are two aspects in considering the response of differential relays to distorted secondary current waveforms as follows:

- a) There is the tendency for unequal ct performance to produce false "operate" current in the relays for external faults.
- b) There is the possibility for severe saturation on internal faults, particularly in the presence of dc offset, which could prevent or delay differential relay operation.

The following subclauses discuss proper ct selection and application in order to avoid these problems.

7.2.2 Generator protection

7.2.2.1 Current transformer selection

The following requirements apply to cts used for generator differential applications:

- a) The ct primary current rating equal to 120% to 150% of the continuous generator current rating shall be selected.
- b) Full-winding ratio shall be utilized.
- c) Cts that have fully distributed secondary windings shall be used.
- d) Cts with the highest practical secondary voltage capability shall be used.

- e) Cts dedicated to the differential protection in order to minimize the burden shall be used. However, this may not be necessary if low burden digital generator protection relays are used for generator protection.
- f) For very high ratio cts, 20 000/5, 4000/5, or higher, cts with compensation windings to minimize the proximity effect shall be specified. See 7.2.2.5.

The differential cts on both sides of a generator should be of the same ratio, rating, connected burden, and preferably have the same manufacturer so that the excitation characteristics are well matched.

7.2.2.2 Gapped current transformers

The characteristics of gapped cts and nongapped cts are dissimilar so they should not be used in the same differential circuit in primary generator protection. However, gapped cts on the neutral-end of an overall generator/transformer differential scheme can be mixed with nongapped cts on the high voltage system because the step-up transformer impedance attenuates the fault magnitude sufficiently.

7.2.2.3 Wye- or delta-connections

When the configuration of the generator allows a choice, wye-connected cts, with the wye-connection at the cts, can be used to reduce circuit burdens. Details of the effects of ct connections are given in 5.6.

7.2.2.4 Inclusion of a generator breaker

If the generator differential zone must include a generator breaker, it is not always possible to use cts with the same excitation characteristics, especially knee-point voltage. The mismatch between cts should be checked.

In order of preference, the goal is to

- a) Avoid ct saturation for asymmetrical currents if possible.
- b) Prevent saturation on symmetrical currents.
- c) Go into saturation at the same current if avoiding dc saturation is not possible.
- d) Minimize the difference in time-to-saturation for asymmetrical currents (dc saturation).

7.2.2.5 Proximity effects

The proximity of a ct to a conductor carrying a high current can affect the performance of the ct. The magnetic flux produced by the adjacent current can induce both phase angle and ratio errors, which can cause incorrect operation of differential schemes under both steady-state (load) and fault conditions.

This phenomenon is discussed by R. A. Pfuntner [B24]. It is a common problem for large diameter, very high ratio cts located on the terminals of large generators where the interphase spacing is small and the primary conductors are very close to the adjacent phase ct secondary windings. In such cases, it is customary to specify cts with "shield" or compensation windings. These are extra segmented windings spaced around the ct core and interconnected with opposing polarities so their linkages with the normal internal core flux cancel out. However, when an external magnetic field due to the current in an adjacent phase conductor couples to the core asymmetrically, the net flux linkage to this field does not cancel and the resulting current flow in the compensation windings produces a counter flux, minimizing the influence of the external field.

Connections between the compensation windings on a ct are made internally by the manufacturer. No connections are brought out from the compensation windings so application of these cts needs no additional consideration.

7.2.2.6 Generator differential relay application

It is impractical to size cts to avoid transient saturation in a generator differential because of the high X/R ratios encountered. The rule is to select the largest practical rating and match the terminal and neutral-side cts. The pitfall is

that the highest ct accuracy class is the C800 and that any ct with an excitation voltage exceeding 800 V is classified C800 no matter how high the voltage. For example, one 6000:5 ct may have an excitation voltage of 1500 V at 10 A of exciting current and be classified C800. A second ct 6000:5 of a different manufacture may have 978 V at 10 A of excitation and also be classified C800. The generator cts must have the same excitation curve with matching knee-point voltage and the same excitation voltage at 10 A excitation current in order to avoid differential error current occurring during an offset through fault condition.

Consider the application of a generator differential relay for a 111 MVA, 13.8 kV generator. The machine has an X/R ratio of 52 and can contribute 58 800 A to an external bus fault. All the cts are classified 6000:5, C800. The continuous current is

$$I_{cont} = \frac{111 \text{ MVA}}{\sqrt{3} \text{ 13.8 kV}} = 4643 \text{ A}$$

and the ct primary rating is selected to be between 120% and 150% of the continuous current rating

$$1.2 \times 4643 = 5572 \text{ A}$$

$$1.5 \times 4643 = 6965 \text{ A}$$

A 6000:5 rating is selected, which is the first standard full winding rating above 5572 A. The ct and the lead resistance for the generator terminal cts were calculated to be 2.6 Ω and 2.3 Ω for the neutral cts with negligible impedance in the restraint windings. Consequently, the maximum ct symmetrical voltage due the maximum fault current is

$$V = \frac{58\,800}{1200}(2.6) = 127 \text{ V}$$

However, the ct would have to support a symmetrical current of $(1 + X/R)$ times this value or $127 \times (1 + 52) = 6731 \text{ V}$ to avoid saturation during the fully offset maximum fault. The largest ANSI rating is C800. For this reason all the cts must be of the same manufacture with knee-point voltages matched as closely as possible so as to experience the same degree of saturation during the offset.

How closely should the knee-point voltages be matched? Consider the application shown in the schematic of figure 14 with a set of generator terminal-side cts having a 500 V knee-point voltage and a set of neutral-side cts having a 552 V knee-point voltage. The knee-point voltage is generally 46% of the excitation voltage occurring at 10 A of excitation. Consequently, the actual rating can be considered to be $500/0.46 = 1087 \text{ V}$ and $552/0.46 = 1200 \text{ V}$, respectively. Figure 15 shows the response of these cts for a 58 800 A fault with maximum offset due to an X/R ratio of 52. In this case, the ct at the generator terminal saturates slightly before the ct on the generator neutral. The slight mismatch of the knee-point voltages and of the lead resistance on each side produces a 50 A pulse current in the operate coil. The pulse, being of short duration and accompanied by restraint current, is not expected to operate the relay. However, the mismatch can be eliminated by increasing the series resistance on the neutral side to equal the 2.6 Ω of the terminal leads times the ratio of the knee-point voltages (552/500) or 2.87 Ω . This case is shown in figure 16. Figure 15 and 16 were obtained by computer simulation using the method explained in [B35]. An alternative would be to reduce the burden of the terminal side cts in order to eliminate the mismatch. However, this is not always possible, especially when the cts are widely separated and the burden is largely composed of the resistance of the cables.

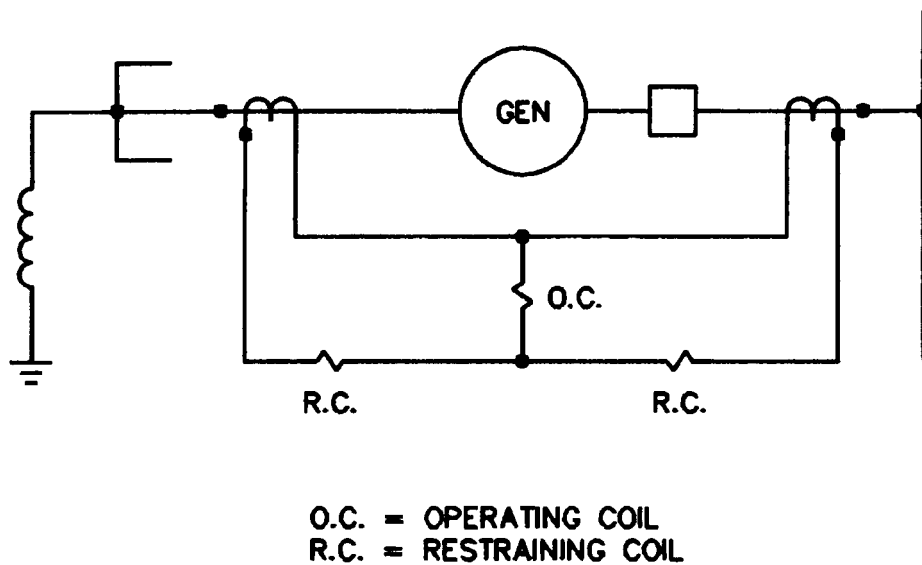

Figure 14—Generator differential application

7.2.3 Transformer protection

7.2.3.1 Current transformer arrangements

Separate relay restraint circuits should be used for each power source to the transformer. If the secondary windings of cts from two or more supply breakers are connected in parallel, under heavy through fault conditions differential current resulting from the different magnetizing characteristics of the cts, will flow in the relay. This current will only flow through one restraint winding and can cause misoperation. If each ct is connected to a separate restraint winding, the total fault current in each breaker provides restraint. Connecting ct secondary windings in parallel is advisable only where both circuits are outgoing loads. The maximum through fault level will then be restricted solely by the power transformer impedance.

7.2.3.2 Current transformer sizing for internal faults

If a ct starts to saturate for internal faults, harmonics will be produced in the secondary waveform. If the relay is of a harmonic restraint type, the differential relay can restrain initially.

As a rule of thumb, ct performance will be satisfactory if the ct secondary maximum symmetrical internal fault current, I_F , multiplied by the total secondary burden, Z , is less than half the C voltage rating of the ct (see 5.10). This allows some room for dc offset (asymmetry) and remanence before the ct saturates.

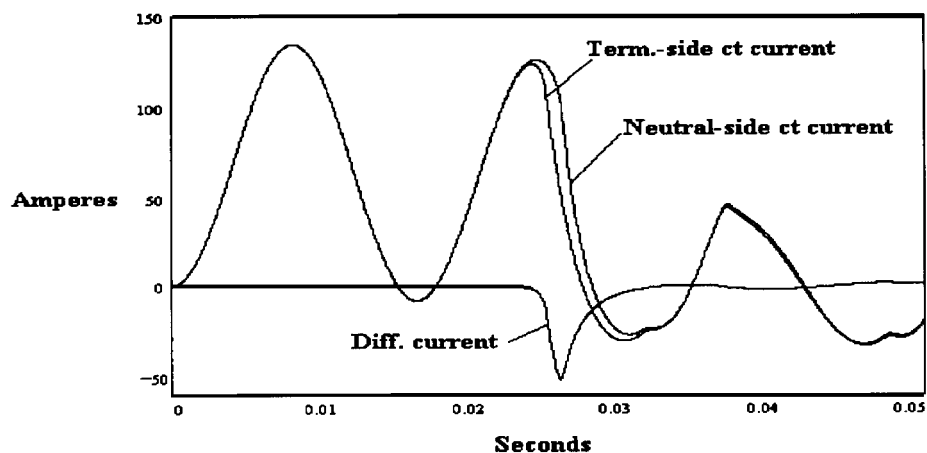

Maximum offset 58 800 A, $X/R = 52$

Figure 15—Secondary current in neutral and terminal side cts with differential current

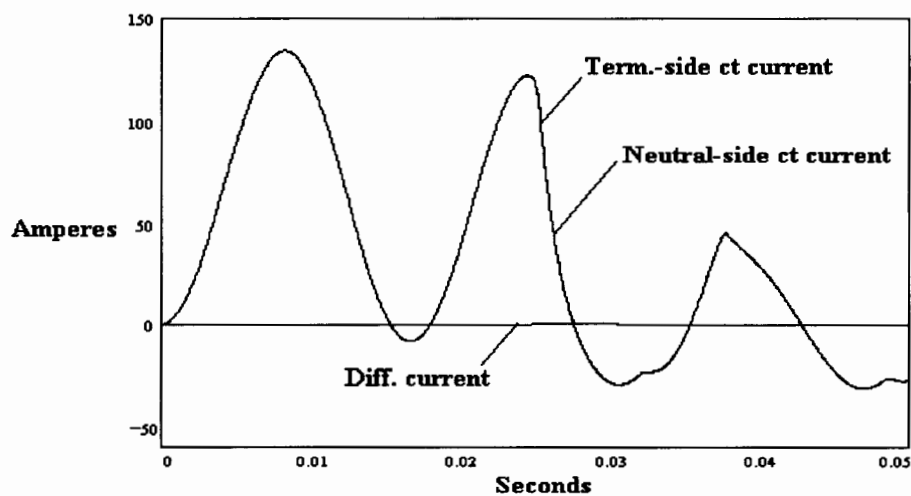

Maximum offset 58 800 A fault current, $X/R = 52$

Figure 16—Secondary current in neutral and terminal side cts with differential current for corrected burden

7.2.3.3 Application procedure

Avoiding ct saturation for the maximum asymmetrical external fault requires cts with a C voltage rating of $(1 + X/R)$ times the burden voltage appearing for the maximum symmetrical external fault where X/R is for the primary system. It may not be possible to satisfy this condition. In applying differential protection, it is important that the high-side cts and the low-side cts are saturated to the same extent for external faults. Therefore, the C voltage ratings should be as high as is practical but should match their respective burdens if relay misoperation is to be avoided.

- 1) Select the high-side ct ratio by considering the maximum high-side continuous current. Let this current be I_{HS} . The choice of ct ratio should ensure that at maximum loading, the continuous thermal rating of the ct, leads, and connected relay burden should not be exceeded. For delta-connected cts the relay current is $\sqrt{3}$ times the ct secondary current. Let this ratio be ctH and be the nearest standard ratio higher than I_{HS}/I , where I is 5 A or a lower value determined by the relay setting.
- 2) Determine the burden on the high-side cts.
- 3) For the high-side ct ratio, select the highest available nominal accuracy class voltage of ct that will exceed twice the product of the total high-side ct secondary burden and the maximum symmetrical high-side ct secondary current, which could be experienced by the ct due to an external fault. If necessary, select a ct ratio higher than that indicated in item 1 above to meet this requirement. For the maximum internal fault, the ct ratio and burden capability should permit operation of the differential relay instantaneous unit before saturation occurs.
- 4) Select a standard low-side ct ratio to provide a secondary current of less than 5 A for maximum load current. Select the relay tap settings to provide a match between the high-side and low-side currents. Where delta-connected cts are used, the relay current is $\sqrt{3}$ times the ct current.
- 5) This procedure should be followed for all power transformer windings. If a ct ratio has been selected on the basis of the reduced MVA rating of a winding, the relay tap settings must be selected for a proper match for the full MVA rating on any two windings. This may require an auxiliary ct to match the available relay tap settings for a winding of reduced MVA rating.
- 6) Calculate $I_{3\phi}$, the maximum symmetrical through-fault current on the power transformer low-side and verify that this quantity does not result in low-side ct secondary current greater than 100 A (20 times rated current, 5 A). If this exceeds 100 A, proportionally increase the nominal ct ratios for the high-side and low-side cts.
- 7) Determine the burden on the low-side cts.
- 8) Select a nominal low-side ct accuracy class voltage for the tap ratio in use that exceeds twice the product of the total low-side ct secondary burden and the maximum ct secondary symmetrical current taking into account the $\sqrt{3}$ factor for delta-connected cts. The ratio of burden voltage to ct voltage capability for the maximum external fault should be about the same for both high- and low-side cts.

7.2.3.4 Application of a transformer differential relay

Figure 17 shows a 4160 V bus supplied by a 5000 kVA 13.8/4.16-kV delta-wye resistance grounded transformer.

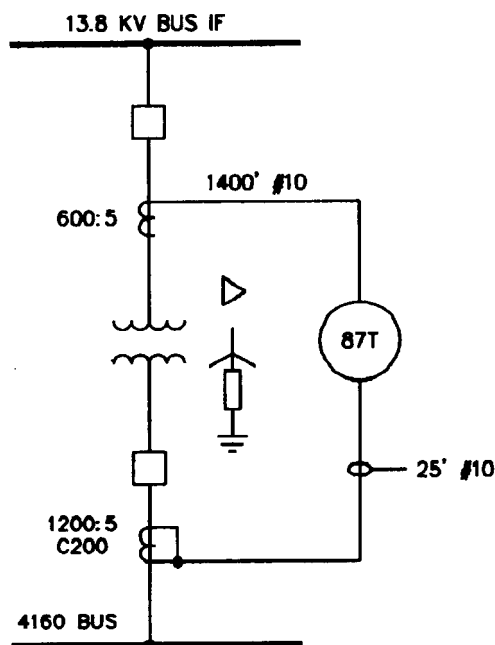

Figure 17—Transformer differential protection

The transformer has a 5% impedance on a 5 MVA base. System and ct data being considered are as follows:

System data	
Description	Value
System X/R	11
Source impedance on 5 MVA base	0.0064 p.u.
13.8 kV ct cable connection (Bus IF)—1400 ft (427 m) (one way) of #10	1.43 Ω
13.8 kV differential relay at tap 2.9	0.1 Ω
4.16 kV ct cable connection—25 ft (7.6 m) (one way) of #10	0.03 Ω
4.16 kV differential relay at tap 8.7	0.02 Ω
4.16 kV ct accuracy class C200 delta-connected	0.5 Ω
13.8 kV ct accuracy class C50 (Option A), wye-connected	0.16 Ω
13.8 kV ct accuracy class C200 (Option B), wye-connected	0.31 Ω

To apply the procedure delineated in the previous paragraph, proceed as follows:

1) To choose the high side ct ratio, allow for the maximum continuous current to which the transformer may be subjected. This includes the highest rating capability of the transformer. The maximum continuous load on the transformer is the nameplate rating of 5000 kVA.

$$I_{HS} = \frac{\text{kVA}}{\sqrt{3} \times \text{kV}} = \frac{5000}{\sqrt{3} \times 13.8} = 209.2 \text{ A}$$

A ct rating of 600/5 is selected to minimize the effect of the long secondary cable.

$$I_{sec} = 209.2/120 = 1.74 \text{ A.}$$

Select the 2.9 A tap for 87 T.

2) If option A is chosen, the total burden on the high side will be

Component	Burden
13.8 kV, C50	0.16 Ω
1400 ft (427 m) #10, one way	1.43 Ω
Differential relay @ 2.9 A tap	0.1 Ω
Total burden	1.69 Ω
Total burden, allowing for 40 °C (1.69 times 1.13)	1.91 Ω
NOTE — The 1.13 multiplier for 40 °C temperature rise would not apply for buried cable.	

3) The maximum three-phase symmetrical fault current through the primary ct for a fault on the low-side terminals is

$$I_f = \frac{\text{kVA}}{\sqrt{3} \times (Z_{xmfr} + z_{source}) \times \text{kV}} = \frac{5000}{\sqrt{3} \times (0.05 + 0.0064) \times 13.8} = 3710 \text{ A}$$

The ct secondary current due to through fault conditions will be

$$I_f(\text{Ct ratio}) = 3710/120 = 31 \text{ A}$$

The required ct voltage will be

$$V_S = 1.91 \times 31 = 59.2 \text{ V}$$

The desired ct accuracy class is twice the above voltage, or 118.4 V. Since the voltage required by the primary ct is higher than the ct accuracy class of C50, the primary ct will saturate.

The use of option B with C200 ct will result in the following:

Component	Burden
13.8 kV, C200	0.31 Ω
1400 ft (427 m) #10, one way	1.43 Ω
Differential relay @ 2.9 A tap	0.1 Ω
Total burden	1.84 Ω
Total burden, allowing for 40 °C temperature rise (1.84 times 1.13)	2.08 Ω

The required voltage will be

$$V_S = 2.08 \times 31 = 64 \text{ V}$$

The C200 ct provides satisfactory performance for the guideline of twice 64 V or 128 V.

4) The maximum continuous low-side current with the taps set on the mid-point or nominal voltage setting will be

$$I_{LS} = \left(\frac{kV_p}{kV_s} \right) \times I_{HS} = \left(\frac{13.8}{4.16} \right) \times 209.2 = 694 \text{ A}$$

A ct ratio of 1200/5 will result in a full-load ct secondary current of (694/240 = 2.89 A). The differential relay current is $\sqrt{3} \times 2.89 = 5.0$ A. A relay tap of 8.7 A provides a match with the primary side within 5%.

5) Since the ct was chosen on the full rating of the winding, this section of the procedure is not applicable.

6) The maximum symmetrical secondary fault current is calculated as follows:

$$I_{3\phi} = \frac{\text{kVA}}{\sqrt{3} \times (Z_{xmf} + Z_{source}) \times \text{kV}} = \frac{500}{\sqrt{3} \times (0.05 + 0.0064) \times 4.16} = 12\,300 \text{ A}$$

The secondary ct current is $I_{3\phi}/240 = 51$ A. This is less than 100 A. Therefore, there is no need to increase the nominal ratios for high-side and low-side cts.

7) Since the 4 kV cts are connected in delta, the burden seen by the secondary ct is as follows:

Component	Burden
4.16 kV, C200	0.5 Ω
25 ft (7.6 m) #10, one way (3 \times 0.03)	0.09 Ω
Differential relay @ 8.7 A tap (3 \times 0.02)	0.06 Ω
Total burden	0.65 Ω
Total burden, allowing for 40 °C temperature rise (0.65 \times 1.13)	0.73 Ω

8) The minimum voltage required by the ct considering the delta connection of the secondaries is

$$V_S = I_S \times R_{\text{burden}} = 51 \times 0.73 = 37 \text{ V}$$

Since the C200 ct capability is more than twice the required maximum symmetrical fault voltage, the ct will not saturate.

This example demonstrates a relatively good match between ct performance and burden on each side of the transformer.

7.2.4 Bus protection

The two most common classifications for bus differential relays are high-impedance and low-impedance relays. There is a relay system made by one manufacturer that is classified as a medium-impedance system and minimizes the need for matched cts. Since this application is not general enough in the US, it is not addressed in this guide.

NOTE — For a more detailed discussion of bus protection systems, see IEEE Std C37.97-1979.

7.2.4.1 High-impedance differential relaying

Differential relaying with special high-impedance voltage relays circumvents the problem of ct saturation during external faults. Bushing or toroidal cts with fully distributed windings and low leakage flux shall be used. All cts should have the same ratio. The highest ratio should be used in order to develop the maximum ct capability (permitting a higher relay setting for security) and to minimize the secondary current, and hence the voltage developed for the heaviest external fault. The basic circuit for this is shown in figure 18.

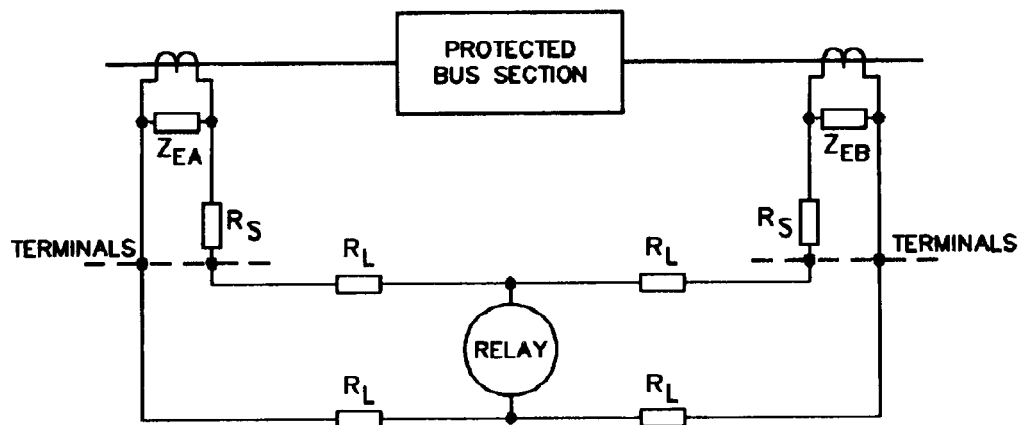

Figure 18—High-impedance bus protection

The relay differentiates between internal and external faults by the relative magnitude of voltage that appears across the differential junction.

For external faults, the ct on the faulted circuit is assumed to saturate completely (worst possibility). The relay sees a voltage equal to the external fault current multiplied by the ct ratio times the resistance of the leads and the secondary winding of the saturated ct. If this voltage is less than the voltage setting of the relay, then the relay will not operate.

For an internal fault, the cts attempt to force secondary current through the high-impedance differential relay and a relatively high voltage is developed to operate the overvoltage unit. The ct lead junction point should be centrally

located in the switchyard to minimize the voltage developed to the relay for an external fault and saturated ct. However, ct junction points at the relay location for convenience in cable routing or using existing cables have been successfully applied where the cable run is relatively short and ct and relay requirements are met.

To express the relay setting requirements, it is then necessary to calculate the voltage appearing across the relay circuit during a maximum external fault with the faulted circuit ct saturated:

$$V_R \geq I_f(R_S + PR_L)$$

where

I_f	is the maximum external fault secondary current
R_S	is the ct secondary winding resistance and leads to housing terminal
P	is 1 for 3 \emptyset fault
P	is 2 for \emptyset -G fault
R_L	is the maximum one way cable resistance from the ct housing terminal to the secondary lead junction point
V_R	is the relay setting voltage

To ensure satisfactory operation of the relay under internal fault conditions, the lowest ct knee-point voltage V_K of any ct connected in the scheme should be at least twice the relay voltage setting, i.e., $V_K > 2V_R$.

For high-impedance relays, the full ct winding should be used for all cts. If one or more cts have an overall ratios in parallel. On internal faults, the higher burden of the relay will result in higher voltage across the ct tap used, and by autotransformer action, a high voltage at the winding end terminal may exceed the capability of the circuit insulation. Also, the secondary current is greater and ct voltage capability is reduced, both of which are objectionable from the relay application and setting standpoint.

Several approaches to permit using cts with different ratios and avoiding excessive voltage are given as follows:

- a) The best solution is to make all ct ratios the same by retrofitting the offending breakers with cts of the proper ratio. If this is not possible because of the continuous current requirement of a particular breaker, a ct of the proper ratio but with a higher thermal rating factor could be specified. For example, if a 3000 A breaker is to be connected to a bus where all other breakers are rated at 2000 A, the 3000 A breaker could be equipped with 2000:5 cts with a thermal rating factor of 1.5.
- b) Another method is to use the higher ratio ct in one circuit breaker for both the differential relay and as an auxiliary ct. The two breakers should be next to each other to minimize the interconnecting cable burden. The disadvantage of this scheme is that when the circuit breaker with the higher ct is out of service and physically removed, the bus protection must be removed from service or the connections moved to another breaker (see figure 19).
- c) The disadvantage of method 2 is avoided by paralleling the low ratio ct to the corresponding taps of higher ratio cts in two or more adjacent breakers. In this way, the higher rated cts act as ratio matching autotransformers for the low ratio ct and either can be removed without affecting the bus relaying (see figure 20).
- d) Another approach is to match the low ct ratio to the higher one with a special auxiliary autotransformer. This auxiliary ct must have distributed windings on a toroidal core similar to a bushing ct and have a C voltage rating adequate for the desired relay setting (see figure 21).
- e) Other solutions to this problem may be applicable. These solutions require modifications to the differential relay voltage limiting circuit rather than the ct connections.

An example of high-impedance bus differential relay application is shown in figure 22. Here a high-impedance relay is applied to a four breaker bus with C800, 3000:5 cts. Each ct has a winding resistance of 1.5 Ω and 100 ft (30.5 m) #14 leads connected to the relay. The relay setting was determined by considering the maximum external fault of 50 000 A and the ct of the faulted breaker completely saturated. The voltage drop across the total lead resistance of 0.523 Ω and the 1.5 Ω winding resistance by the 83.33 A secondary current was calculated as 168.6 V. A factor of 2 was

applied for asymmetry and errors, giving a calculated value of 337 V. The nearest setting of the relay used is 400 V at 2210 Ω .

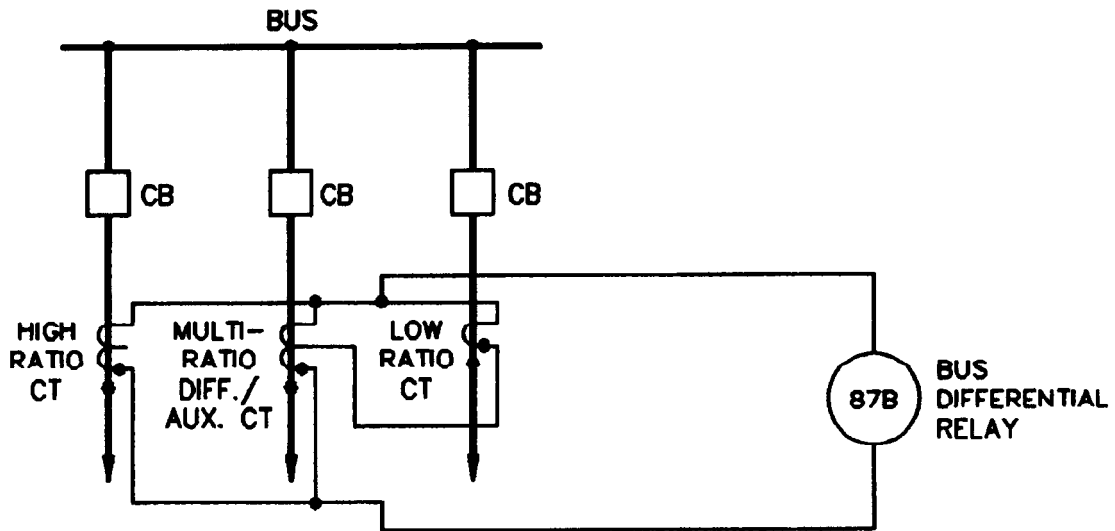

Figure 19—High-impedance bus differential using one multi-ratio differential/auxiliary ct

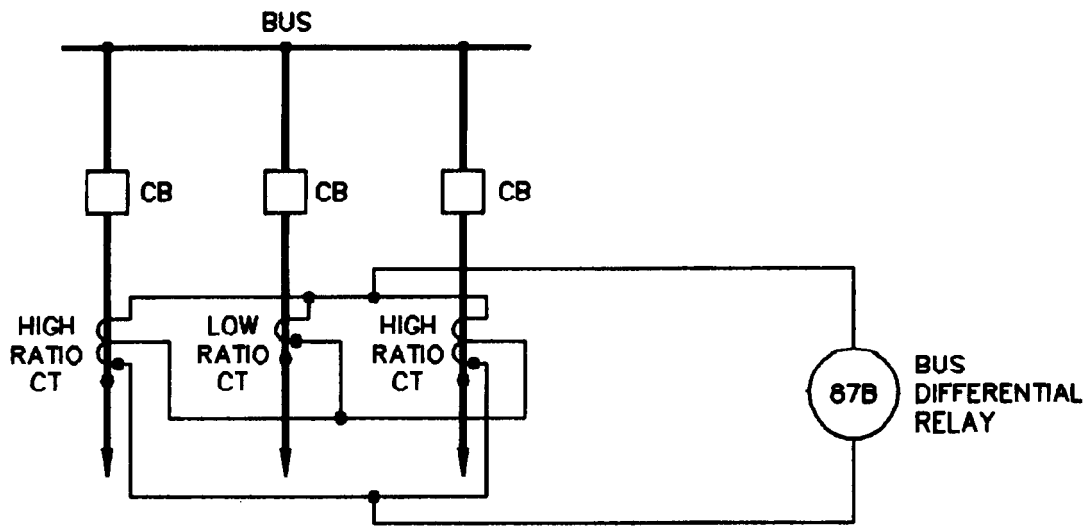

Figure 20—High-impedance bus differential

This case was analyzed using the two breaker model, as in figure 23.

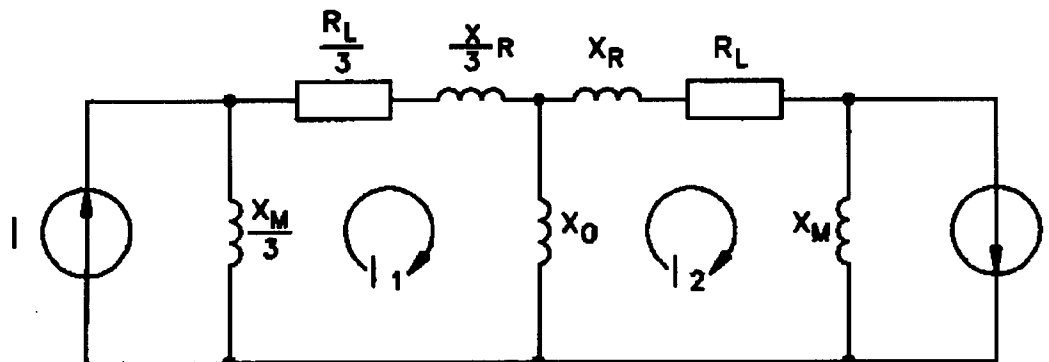

Figure 23—Equivalent circuit of 3 cts supplying current to 1 ct

The model uses an equivalent C800, 3000:5 ct to represent the three unfaulted breaker cts while the external fault was applied to the fourth breaker. The model of the equivalent ct has the same saturation voltage and one third the magnetizing impedance as shown in the figure. Figure 24 shows that less saturation occurs due to the dc offset because of the high-impedance of the relay than would occur with a low-impedance relay using the same cts and leads as shown in figure 29. Consequently, there is virtually no difference between the total current from the unfaulted cts, trace I_1 , and the current to the faulted ct, trace I_2 . Figure 25 shows the difference current for the case where the peak current is less than 0.1 A and the trip value for the relay, calculated from the 400 V 2210 Ω relay setting, is 0.255 A peak.

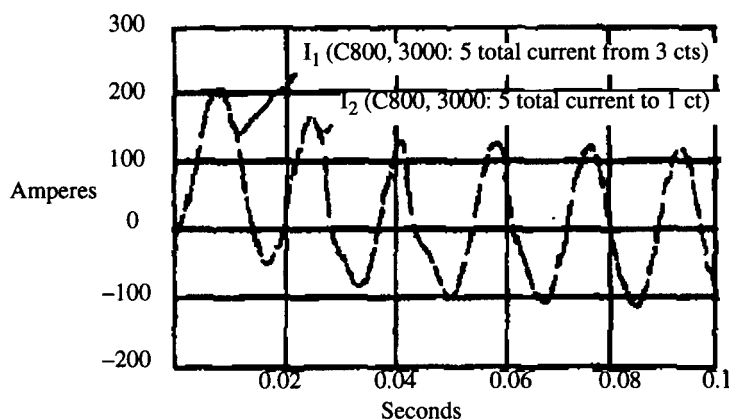
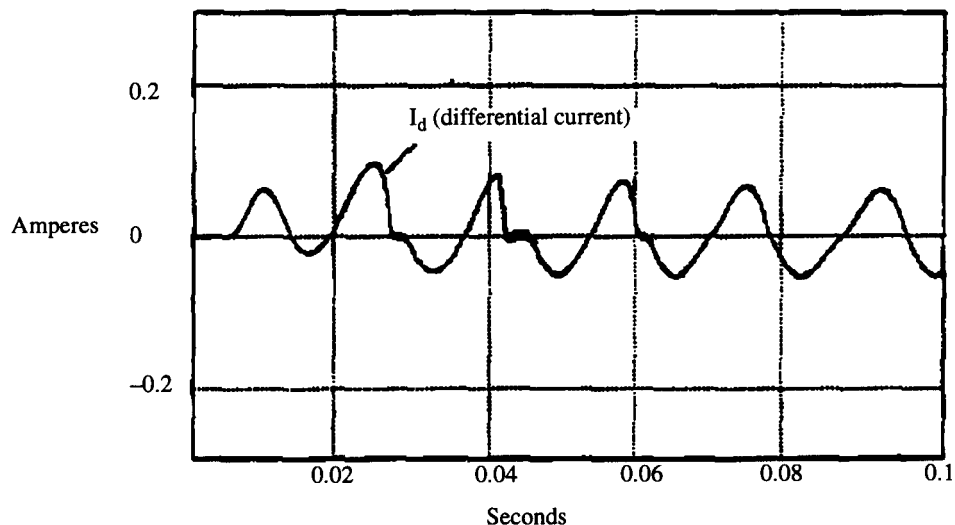

Figure 24—Secondary current for a 50 000 A external fault, bus differential relay with a 400 V 2210 Ω setting



The relay trip level is 0.255 A peak.

Figure 25—Operating current in high-impedance bus differential relay for a 50 000 A external fault on a four-breaker bus with C800, 3000:5 ct

Figures 26 and 27 show the trip condition for the minimum internal fault with only one breaker closed where the minimum fault current was found to be 500 A of primary current. Figure 26 shows the secondary current of the closed breaker, Trace I_1 . Trace I_2 is the total magnetizing current supplied to the cts of the open breakers. Figure 27 shows the difference current exceeds the 0.255 A relay trip level. The wave distortion is due to the high content of magnetizing current.

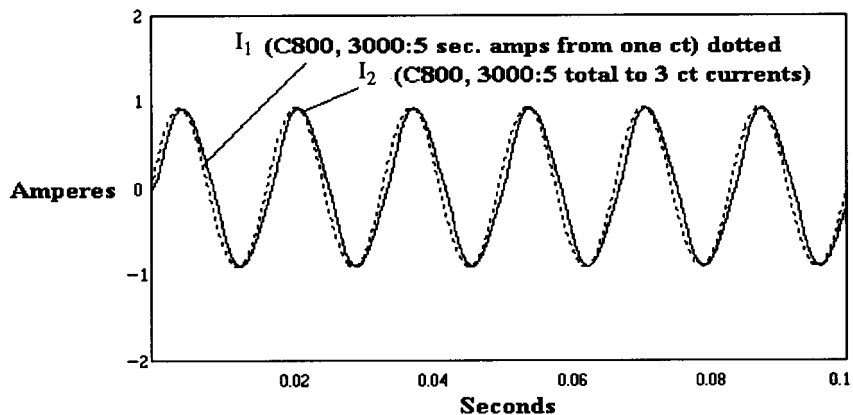

Figure 26—Secondary current for a 500 A minimum internal fault, bus differential relay with 400 V, 2210 Ω setting

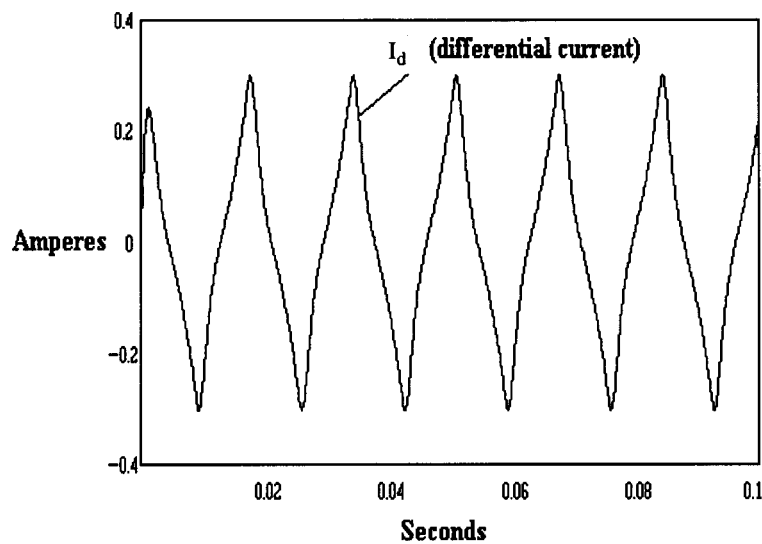

Figure 27—Operating current in a high-impedance bus differential relay (trip level 0.255 A peak) for a 500 A four-breaker bus

7.2.4.2 Low-impedance overcurrent differential relaying

There are several schemes for differential protection using low-impedance overcurrent relays. The simplest uses induction disk overcurrent relays. Other schemes use percentage restraint and variable percentage restraint overcurrent relays that offer the advantages described in the paragraphs below. For new installations, cts compatible with the chosen scheme should be selected. For existing installations, the scheme that is compatible with the existing cts should be chosen. If possible, change existing cts for the desired performance.

Simple induction disk overcurrent relays can be installed to measure the difference of the ct outputs on each phase of the bus protected. The difference current can be determined by paralleling the ct leads in the switch-yard or at the relay house. The connection is like that for high-impedance differentials described in 7.2.4.1. CTs of the same ratio should be used. A fourth relay measuring the residual of the three-phase relays can be used to provide sensitive tripping for bus ground faults. Auxiliary cts to compensate for unequal ct ratios should be avoided unless the auxiliary cts' performance is sufficient to drive the relays' burden for the expected fault current.

While the above scheme is simple, care should be taken to avoid ct saturation for external faults. CT ratios, burdens, and accuracy class voltage should be selected to avoid ct saturation. CTs close to generating stations are more likely to saturate due to higher X/R ratios and the resulting longer dc offset time constants. Any difference current due to saturation basically represents the magnetizing current lost in the saturated ct. This difference current can cause the overcurrent relay to operate. False operations can be minimized by using long time delays and high pickup values for the disk element. This limits the relay's speed and sensitivity.

When ct saturation cannot be avoided, multi-restraint percentage differential relays often are used to compensate for the error current. An operating restraint coil in each ct circuit or combination of circuits helps prevent operation for heavy through fault currents. The relay's characteristics make it less sensitive to error current because a certain percentage of differential current compared to restraint current is allowed before tripping. The restraint windings usually have much lower impedance than the current cable leads, so adding the restraint does not add a burden penalty to ct performance. However, with these relays, each current circuit should be brought into the relay and not paralleled in the switchyard. Again, identical ct ratios should be used and auxiliary cts should be avoided.

Further security will result from using variable percentage multi-restraint relays. Therefore, the percentage of error current it takes to operate the relay increases as the error current increases in magnitude.

An example of the variable percentage restraint application uses a four breaker bus with 3000:5, C800 cts with 1.5Ω winding resistance on each breaker as shown in figure 28. The total loop resistance for 100 ft (30.5 m) of #14 wire is 0.523Ω for each ct. The relay restraint elements have an impedance of $0.015 + j0.025 \Omega$ and the operating coil is modeled by a 10Ω reactance with a saturation voltage of 15 V. Consequently, the 83.33 A due to the maximum external 50 000 A fault causes a voltage drop of 170 V across the winding resistance, leads, and restraint coil impedance. The cts appear adequately rated since the C800 rating is about 4.7 times the symmetrical secondary fault voltage. However, the rating is not sufficient to prevent saturation during the exponential decay of an asymmetrical fault current.

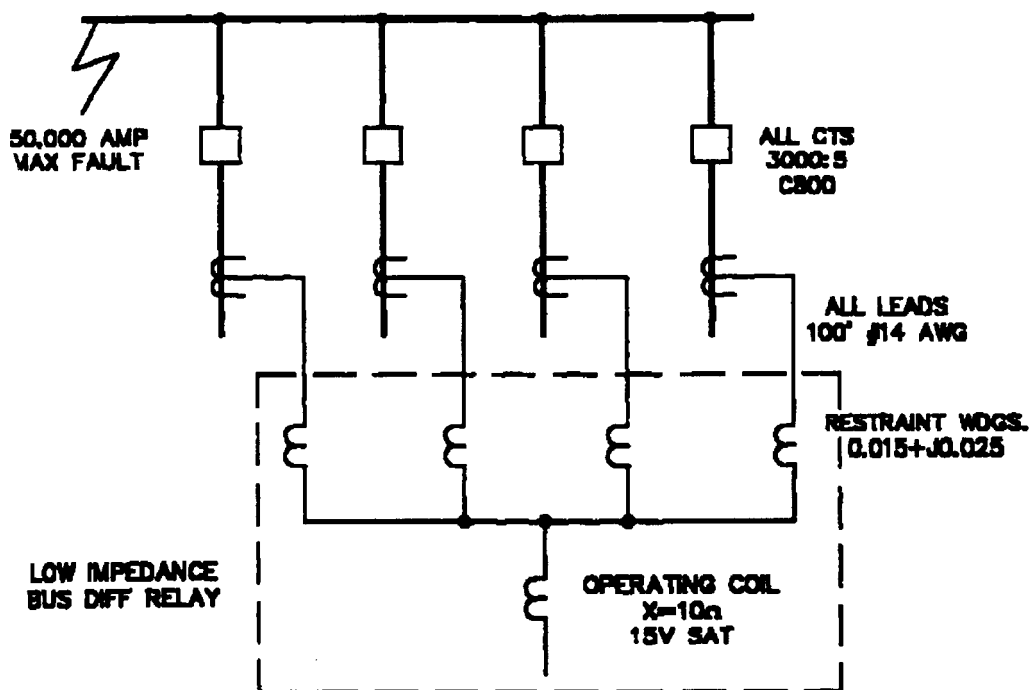

Figure 28—Low-impedance bus differential application

To create a simple two breaker model, an equivalent 3000:5 C800 ct was used to represent the three unfaulted breakers while an external fault was applied to the fourth breaker (see figure 23). The model of the equivalent ct has the same saturation voltage and one-third the magnetizing impedance as shown in the figure.

In figure 29, the unfaulted ct combined outputs are shown by Trace I_1 . The ct on the faulted breaker saturates and is shown by Trace I_2 . The difference current seen by the relay operating circuit is shown by Trace I_d . The difference current, while significant in magnitude, produces only short blips of current and decays before the relay has chance to operate. Buses with lower fault currents, higher ct ratios, or better accuracy class cts would have even more security against false tripping.

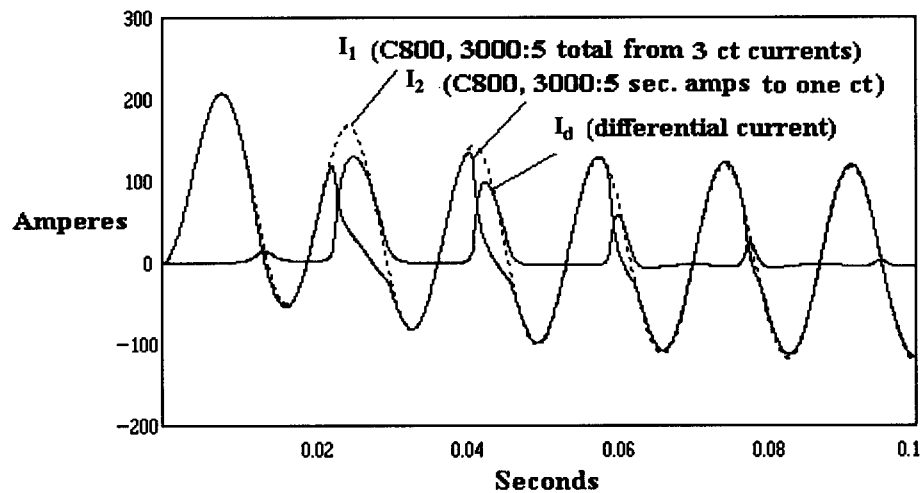

Figure 29—Secondary current for a 50 000 A external fault on a four-breaker bus showing saturation in the faulted ct and the differential current in the relay operating coil

Some overcurrent differential relays are augmented by a clapper type ac instantaneous relay to quickly detect heavy internal faults. The relay is set at or above one half of the maximum external fault current for any breaker. The clapper will not operate even if the ct on the faulted line completely saturates and produces secondary current during alternate half cycles.

For all of the above low-impedance bus differential schemes, some past practices included the addition of a resistor ($2\ \Omega$ to $20\ \Omega$) in series with the operating coil of the relay. This practice was used when cts of various accuracy class voltage ratings were connected to the same differential, and the bus could experience heavy through faults. The extra burden presented by the resistor caused the various rated cts to saturate at approximately the same time. The resistance value shall not be so high as to prevent the relay from operating for internal faults. Improvement is also obtained by reducing the cable burden associated with the low rated ct by paralleling conductors.

7.3 Distance protection

Distance relays are used in many different types of protection schemes and operate on many different operating principles; hence, it is not possible to give a specific guide on how to select cts for them without knowing the relay type and its application. Therefore, only some of the most important factors are enumerated. They may or may not apply in a specific application.

Laboratory tests and operating experience have shown that ct related waveform distortion can result in erroneous distance relay performance in the following three ways:

- cause underreaching
- reduce the speed of operation
- result in a loss of directionality

The latter type of failure is considered to be the most critical on the high-voltage transmission systems.

The risk of false tripping of line protection for bus faults is particularly critical in ring or breaker-and-a-half bus arrangements. In this case, the current signal for the relay is derived by summing the output of two cts. In the case of bus faults, the currents should add up to the line current, which normally is much less than the fault current. If the cores are left with remanence magnetism in them, and the fault has a large dc component, the distance relays could be presented with large error currents.

7.4 Other types of high-speed protection

The effects on these relay systems due to ct saturation can be most serious because of their operating speed, the configuration of ct sources, and the need for exactly the same performance at each location of the relaying systems.

The relay operating speed is typically 8–25 ms. In many cases the relay may have operated before any saturation effects take place. However, on an external fault, although saturation is less likely, the system will be dependent upon correct ct operation throughout the fault period.

Most phase comparison systems are designed to accept substantial phase angle errors without undue effects. A more likely source of problem is distortion of the phase quantity magnitudes.

Directional comparison systems will have performance problems similar to stand-alone directional instantaneous elements. One difference is that instead of just one or two cts affecting the devices performance, the cts at both ends are involved, so there may be as few as two or as many as six cts involved.

Annex A IEC standards on current transformers (Informative)

The performance requirements of cts are specified in IEC 185 (1987). This standard covers the general requirements applicable to all cts and covers the additional requirements of the protective, Class P, cts. The accuracy requirement of this class of ct is similar to the ANSI Class T ct. In a separate document, IEC 44-6 (1992), four other protective ct classifications are defined for cts where the accuracy requirements are more stringent and cover the transient performance in considerable detail. This is referred as TP classification. The following is a brief summary of the IEC methods of classifying protective ct accuracy.

a) Accuracy of the IEC Class P current transformers

The accuracy limits for Class P cts are defined with symmetrical primary current in terms of maximum composite error at a specified multiple of the rated current with a specified burden in VA (S_b). The procedure and the syntax is illustrated by showing how an ANSI T400 ct would be designated in IEC terminology.

IEEE Std C57.13-1993 classifies protection cts with a specified secondary terminal voltage across a standard impedance (Z_b). The accuracy class rated voltage is measured with 20 times rated steady-state symmetrical current, and the limit of acceptable composite ratio error is 10% (refer to 4.4 for details). For example, a ct with ANSI accuracy classification T400 would be classified in IEC terminology as a 100 VA, Class 10P20 ct, because

$$Z_b = \frac{V_{acr}}{20I_n} = \frac{400}{100} = 4 \Omega$$

where

S_b	is $Z_b \times I_n^2 = 100$ VA
10	is the percentage composite error limit
P	defines the ct as a protection ct
20	is the accuracy limit factor

The standard IEC values for the error limit are 5 or 10. Standard values for the accuracy limit factors are 5, 10, 15, 20, and 30.

b) Accuracy of the IEC Class TP current transformers

There are four different TP classifications to meet different functional requirements as follows:

- Class TPS low leakage flux design ct
- Class TPX closed core ct for specified transient duty cycle
- Class TPY gapped (low remanence) ct for specified transient duty cycle
- Class TPZ linear ct (no remanence)

The error limit for TPS ct in terms of turn ratio error is $\pm 0.25\%$ and the excitation voltage under limiting conditions should not be less than the specified value; furthermore, this value is such that an increase of 10% in magnitude does not result in an increase in the corresponding peak instantaneous exciting current exceeding 100%. In other words, the ct should not be in saturated state at the specified maximum operating voltage.

For TPX, TPY, and TPZ transformers, the error limit is summarized in the table below.

Class	At rated current		At accuracy limit condition
	Ratio Error %	Phase displacement minimum	Peak instantaneous error %
TPX	± 0.5	± 30	10
TPY	± 1.0	± 60	10
TPZ	± 1.0	180 ± 18	10 (see note)
NOTE — Alternating current component error.			

The accuracy limit conditions are specified on the rating plate. The required rating plate information is shown in the table below. (The obvious information such as rated primary and secondary currents are not shown).

CT class	TPS	TPX	TPY	TPZ
Symmetrical short-circuit current factor	X	X	X	X
Rated resistive burden (R_b)	X	X	X	X
Secondary winding resistance (at .. °C)	X	X	X	X
Rated transient dimensioning factor	—	X	X	X
Steady-state error limit factor	X	—	—	—
Excitation limiting secondary voltage	X	—	—	—
Accuracy limiting secondary exciting current	X	—	—	—
Factor of construction*	—	X	X	X
Rated secondary loop time constant	—	—	X	—
Specified primary time constant (T_p)	—	X	X	X
Duty cycle	—	X	X	—

X = applicable, — = not applicable

*The factor of construction is determined from the following ratio:

$$\frac{\text{Equivalent secondary accuracy limiting voltage } (V_{alc})}{\text{Equivalent secondary accuracy limiting e.m.f } (E_{alc})}$$

where

V_{alc} is the rms value of sinusoidal voltage of rated frequency, which, if applied to the secondary winding of a ct, would result in an exciting current corresponding to the maximum permissible error current appropriate to ct class

E_{alc} is the equivalent rms emf of rated frequency determined during direct test when observed error current corresponds to the appropriate limit for the class

Annex B List of IEEE standard C values and burdens (Informative)

The following table is extracted from IEEE Std C57.13-1993.

Table 2 – Standard relaying burdens for current transformers with 5 A secondaries

Burden designation	Resistance (Ω)	Inductance (mH)	Impedance (Ω)	Volt as at 5 A	Power factor
B-1	0.5	2.3	1.0	25	0.5
B-2	1.0	4.6	2.0	50	0.5
B-4	2.0	9.2	4.0	100	0.5
B-8	4.0	18.4	8.0	200	0.5

The standard C ratings correspond to the values of the standard burdens with a current of 100 A, i. e., C100, C200, C400, and C800.

Annex C Remanent flux in current transformers (Informative)

When a fault occurs on a power system, a dc transient can occur in the current waveform depending on the point of incidence of the fault. When a dc transient occurs, the resulting flux in the line cts increases to a level substantially higher than that caused by symmetrical currents.

Usually, the fault current will be interrupted in a few cycles. The fault current duration can be much shorter than the time constant of the primary circuit. The result is a remanent flux in the ct core that can only be removed by demagnetization. It will not be affected by normal load current.

A survey of 141 cts on a 230 kV system revealed the following:

Remanent flux % of saturation	Percentage of cts
0–20	39
21–40	18
41–60	16
61–80	27

Annex D Bibliography (Informative)

This listing of books, articles, and standards is provided as sources for additional information.

- [B1] ANSI C57.13.2-1991, Conformance Test Procedures for Instrument Transformers.
- [B2] Blackburn, J. L., "Ground Relay Polarization," *AIEE Transactions*, vol. 71, Part III, pp. 1088–1093, Dec. 1952.
- [B3] Blackburn, J. Lewis, *Protective Relaying, Principles, and Applications*, New York: Marcel Decker, Inc., Chapters 5 and 8, 1987.
- [B4] Conner, E. E., Wentz, E. C., and Allen, D. W., "Methods for Estimating Transient Performance of Practical Current Transformers For Relaying," *IEEE Transactions on Power Apparatus and Systems*, vol. 94, no.1, pp. 116–122, Jan./Feb. 1975.
- [B5] Douglas, D. A., "Current Transformer Accuracy with Asymmetric and High Frequency Fault Currents," *IEEE Transactions on Power Apparatus and Systems*, vol. 100, no. 3, pp. 1006–1011, March 1981.
- [B6] Elmore, Waiter A., "Current Differential and Phase Comparison Relaying Compared with Pilot Distance Schemes," *Forty-seventh Annual Protective Relaying Conference*, Texas A&M University, March 1994.
- [B7] Englehardt, K. H., "EHV Shunt Reactor Protection—Application and Experience," *10th Annual Western Protective Relay Conference*, Oct. 1983.
- [B8] Forford, T. and Linders, J. R., "A Half Cycle Bus Differential Relay and Its Application," *IEEE Transactions on Power Apparatus and Systems*, vol. 93, no. 4, pp. 1110–1120, July/Aug. 1974.
- [B9] Forford, T. and Linders, J. R., "Application of a High Speed Differential Relay for Buses, Machines, and Cables," *Third Annual Western Protective Relay Conference*, Spokane, WA, Oct. 1976.
- [B10] Garrett, R. M., Kotheimer, W. C., and Zocholl, S. E., "Computer Simulation Of Current Transformers And Relays For Performance Analysis," *14th Annual Western Protective Relay Conference*, Spokane, WA, Oct. 1987.
- [B11] General Electric Co., "Application of PVD Relays Using Different Ratio Current Transformers," GET-6455, General Electric Co., 1981.
- [B12] GEC Measurements, "Protective Relays Application Guide," *GEC Measurements*, The General Electric Co., p.l.c., of England, Chapter 5, 1975.
- [B13] IEEE Std C37.102-1995, IEEE Guide for AC Generator Protection (ANSI).
- [B14] IEEE Std C57.13.1-1993, IEEE Guide For Field Testing of Relaying Current Transformers (ANSI).
- [B15] IEEE Std C57.13.3-1983 (R1990), IEEE Guide for the Grounding of Instrument Transformer Secondary Circuits and Cases (ANSI).
- [B16] IEEE Committee Report, "Gapped Core Current Transformer Characteristics and Performance," *IEEE Transactions on Power Delivery*, vol. 5, no. 4, pp. 1732–40, Nov. 1990.
- [B17] IEEE Power Engineering Society, "Sine Wave Distortions on Power Systems and the Impact on Protective Relaying," *IEEE Special Publication*, TH0115-6-PBM, 1984.

[B18] IEEE Power Engineering Society, "Transient Response of Current Transformers," *IEEE Special Publication*, 76-CH1130-4 PWR, Jan. 1976.

NOTE — For summary, see *IEEE Transactions on Power Apparatus and Systems*, vol. 96, no. 6, pp. 1809–1814, Nov./Dec. 1977.

[B19] Iwanusiw, O. W., "Remanent Flux in Current Transformers," *Ontario Hydro Research Quarterly*, vol. 22, no. 3, pp. 18–21, 3rd Quarter, 1970.

[B20] Lachman, M. F., "Current Transformer Field Testing as Applied to Relay Protection," *Minutes of the Fifty-Seventh Annual International Conference of Doble Clients*, 1990.

[B21] Mason, C. R., *The Art and Science of Protective Relaying*, New York: John Wiley & Sons, Chapters 10 & 13, 1956.

[B22] McConnell, A. J., "The Transient Performance of Current Transformers and Its Effect on Relays," *Illinois Institute of Technology Protective Relay Conference*, 26–27 Apr. 1956.

[B23] Patel, T. U., "Auxiliary Current Transformers in Protective Schemes," *Protective Relaying Committee of the Electric Council of New England*, 30 Apr. 1971.

[B24] Pfuntner, R. A., "Accuracy of Current Transformers Adjacent to High Current Buses," *AIEE Transactions*, vol. 70, part II, pp. 1656–1662, 1951.

[B25] Smaha, D. W. and Hicks, A. B., "A Review of Current Transformers Accuracy and Application Fundamentals," *Georgia Institute of Technology Protective Relaying Conference*, 4 May 1984.

[B26] Smolinski, W. J., "Design Considerations in Application of Current Transformers for Protective Relaying Purposes," *IEEE Transactions on Power Apparatus and Systems*, vol. 92, no. 4, pp. 1329–1336, July/Aug. 1973.

[B27] Vandergrift, J., "Current Transformer Performance Calculations," *Georgia Institute of Technology Protective Relaying Conference*, May 19–20, 1955.

[B28] Weers, Delbert D., "Effect of Burden on Instrument Transformers and How to Size CTs with Rating Factors," *Proceedings of the Minnesota Power Systems Conference*, 2–4 October, 1990.

[B29] Wentz, E. C., and Alien, D. W., "Help For The Relay Engineer In Dealing With Transient Currents," *IEEE Transactions on Power Apparatus and Systems*, vol. 101, no. 3, pp. 519–25, March 1982.

[B30] Wentz, E. C. and Sonneman, W. K., "Current Transformers and Relays for High Speed Differential Protection, with Particular Reference to Offset Transient Currents," *AIEE Transactions*, vol. 59, pp. 481–488, Aug. 1940.

[B31] Westinghouse Electric Corp., *Applied Protective Relaying*. Newark, NJ: Westinghouse Electric Corp., Chapters 5, 6, and 10, 1976.

[B32] Westinghouse Electric Corp. *Relaying Current Transformer Application Guide*, Westinghouse Electric Corp., May 1982.

[B33] Zocholl, S. E., Kotheimer, W. C., Tajaddodi, F. Y., "An Analytic Approach to the Application of Current Transformers for Protective Relaying," *15th Annual Western Protective Relay Conference*, October 1988.

[B34] Zocholl, S. E. and Kotheimer, W. C., "CT Performance in Critical Relay Applications," *17th Annual Western Protective Relay Conference*, Oct. 1990.

[B35] Zocholl, S. E. and Smaha, D. W., "Current Transformer Concepts," *46th Annual Georgia Tech Relay Conference*. pp. 7-9; 29 Apr.-1 May 1992.